









Assembly Instructions









43147755 Panelled Tall Storage Unit

WARNING: DO NOT USE THIS UNIT UNLESS ALL BOLTS AND SCREWS ARE FIRMLY SECURED. DO NOT KNOCK OR DRAG THIS UNIT. USE ONLY ON A FLAT SURFACE. FAILURE TO FOLLOW THESE WARNINGS COULD RESULT IN SERIOUS INJURY. THIS PACKAGE CONTAINS SMALL PARTS AND SHARP POINTS, KEEP AWAY FROM CHILDREN AND BABIES.

MAXIMUM TOTAL LOADING WEIGHT: 5KG FOR EACH SHELF, 20KG IN TOTAL.

Hardware list

	a		24PCS
	b		24PCS
	c	6X30mm	20PCS
	d	4X30mm	5PCS
	e		1PC
	f	3X14mm	14PCS
	g		1PC
	h		1PC
	i	4X10mm	1PC

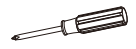
	j		1PC
	k	3X12mm	9PCS
	m		1PC
	n	4X14mm	1PC
	o		2PCS
	p		4PCS
	q		12PCS
	r		24PCS
	Tool required Philips Head Screw Driver (Not Provided)		

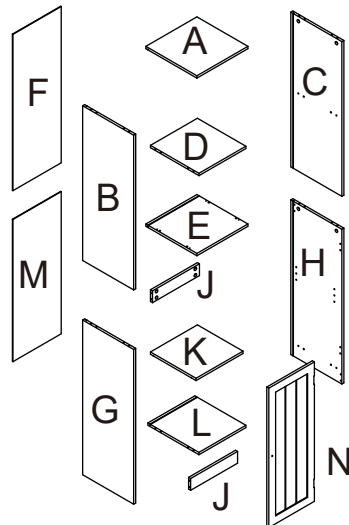

DO NOT TIGHTEN THE SCREWS UNTIL THE PRODUCT IS FULLY ASSEMBLED.

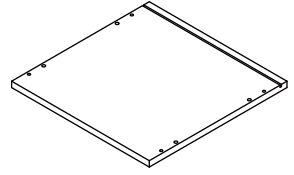
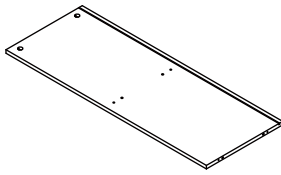
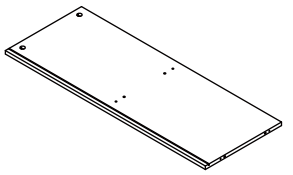
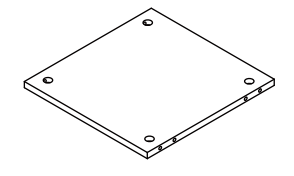
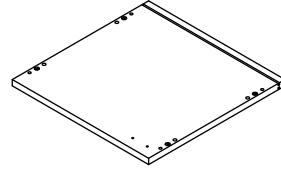
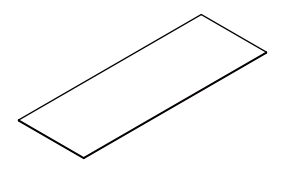
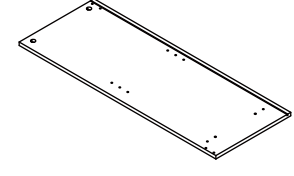
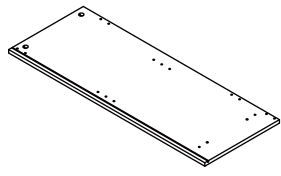
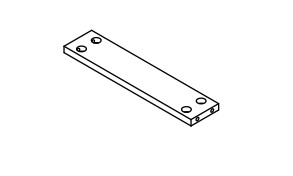
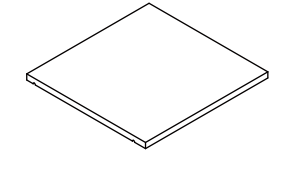
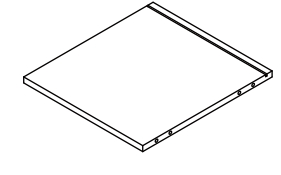
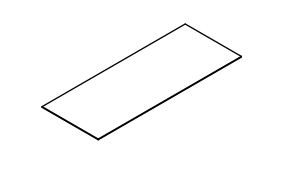
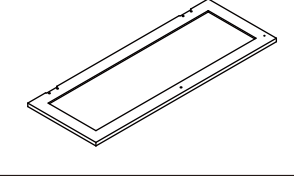
					
A	1 PC	B	1 PC	C	1 PC
					
D	1 PC	E	1 PC	F	1 PC
					
G	1 PC	H	1 PC	J	2 PCS
					
K	1 PC	L	1 PC	M	1 PC
					
N	1 PC				

STEP 1

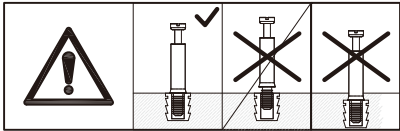
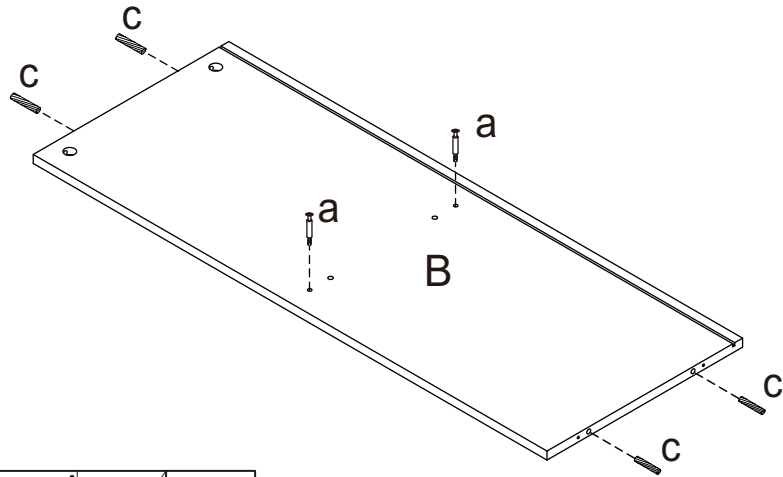

STEP 2

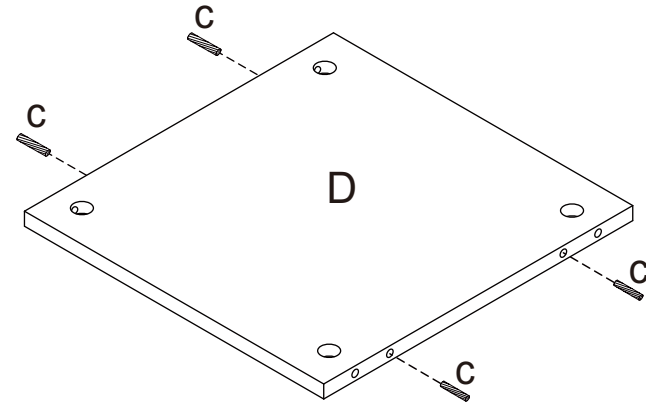

STEP 3

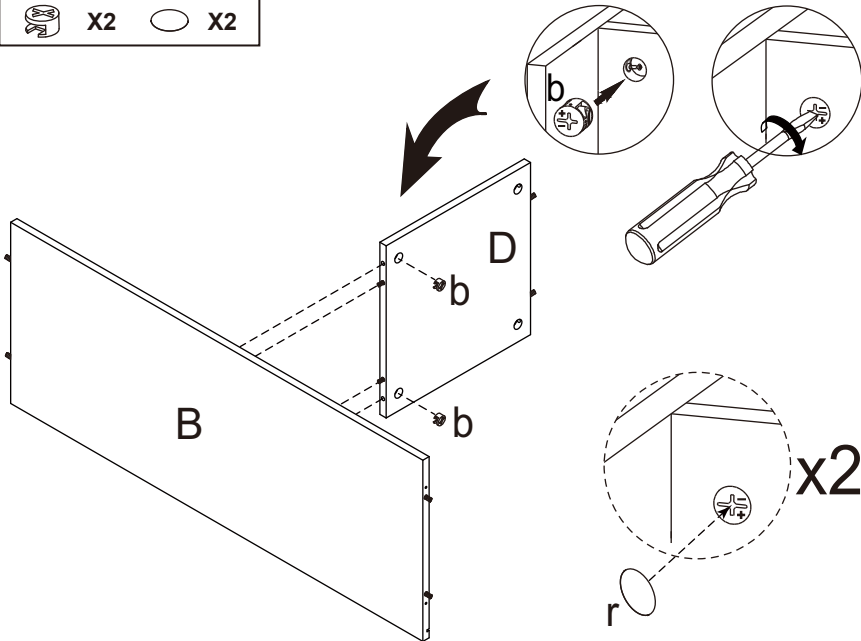

STEP 4

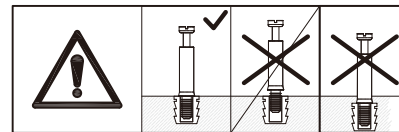
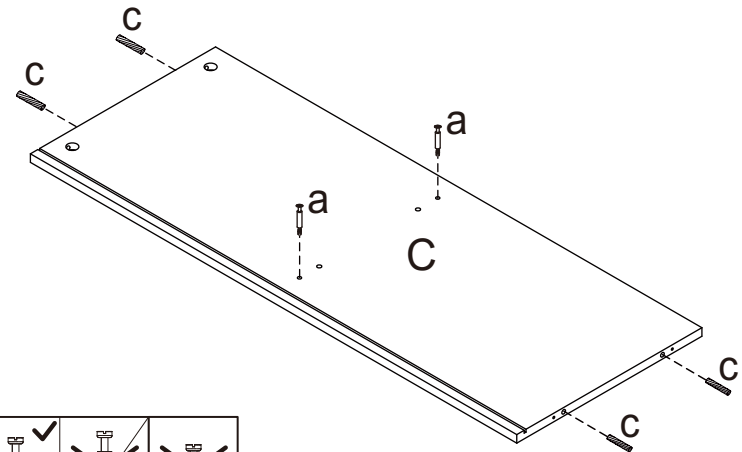

STEP 5

 X2  X2

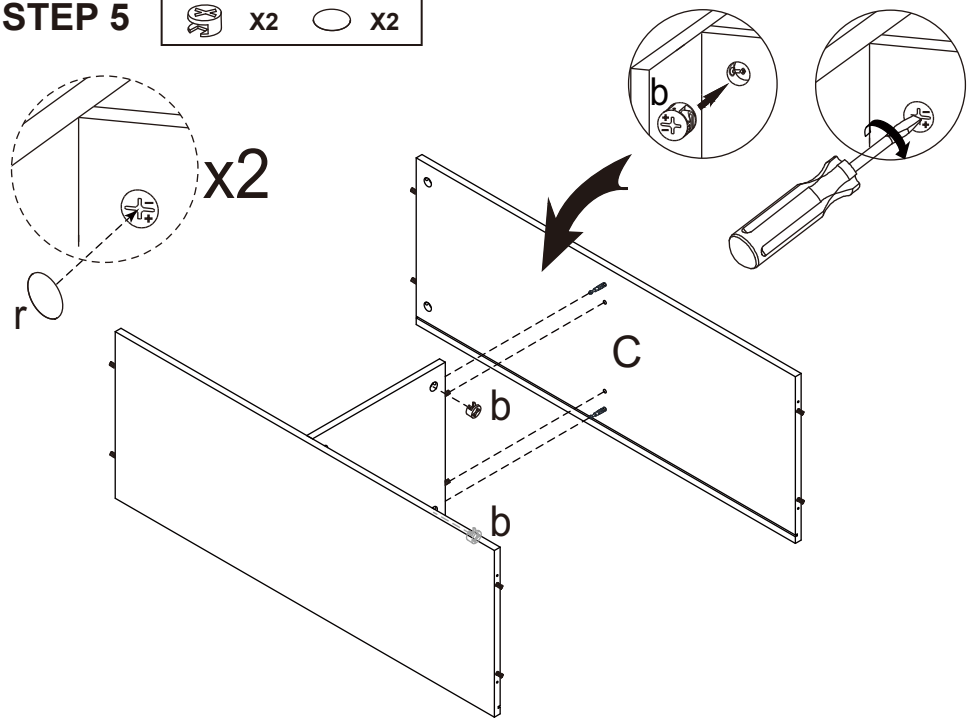

STEP 6

 X4

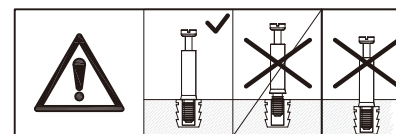
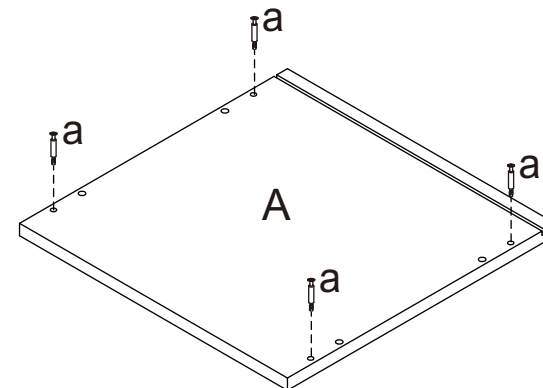

STEP 7

 X4  X4

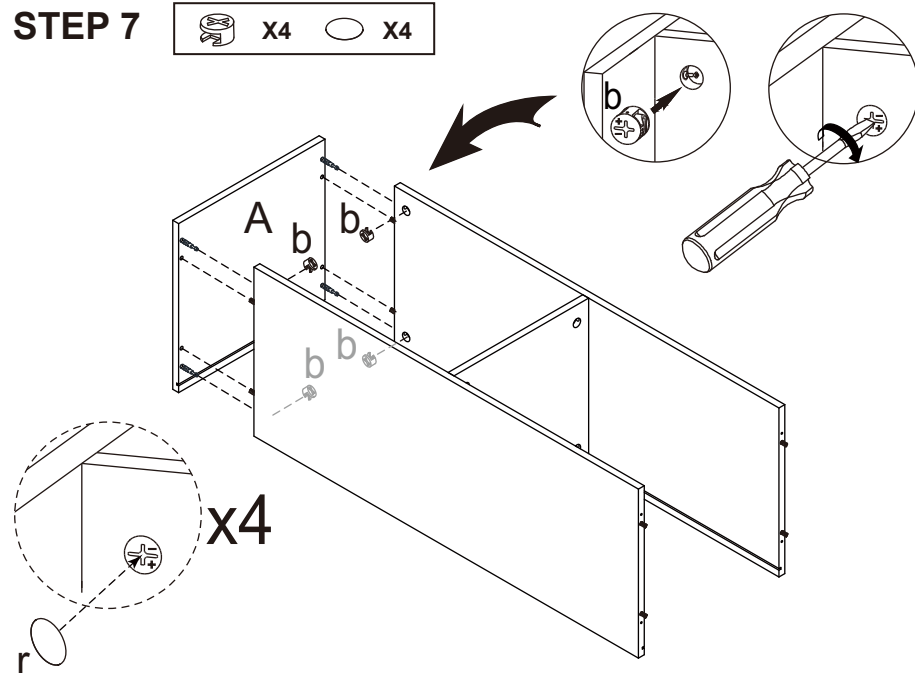

STEP 8

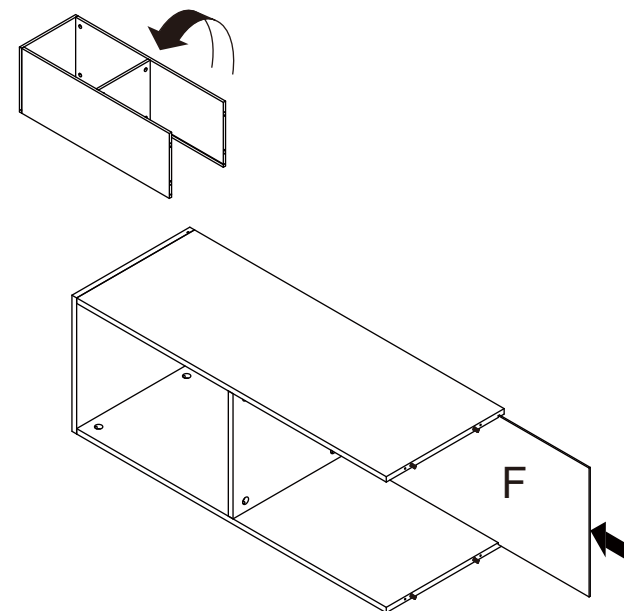

STEP 9

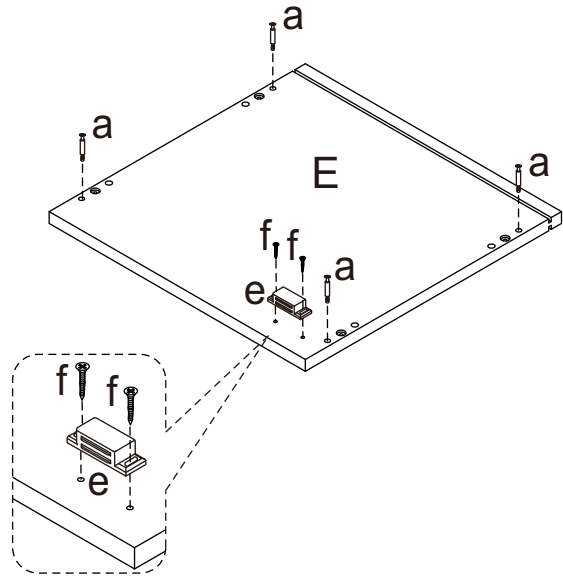
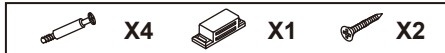

STEP 10

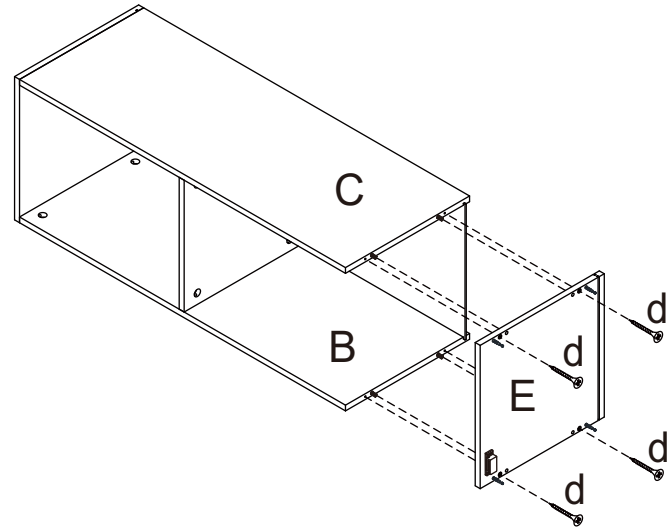

STEP 11

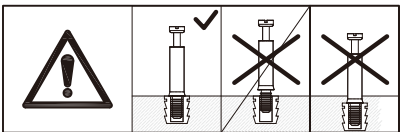
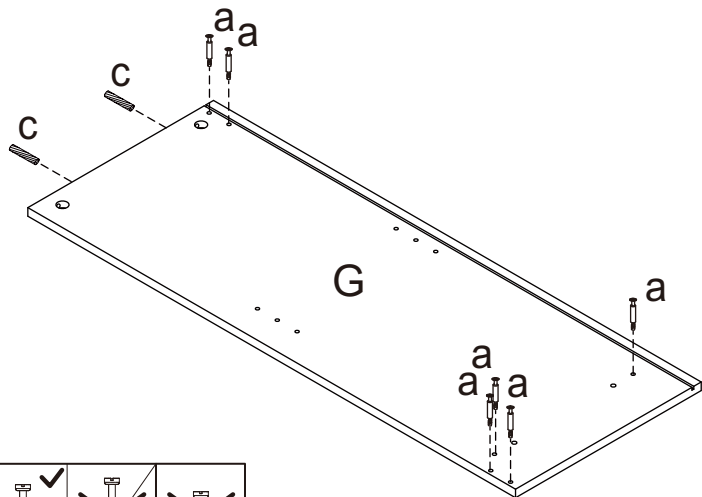

STEP 12

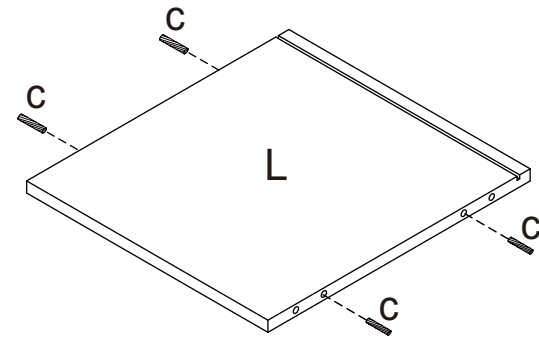

STEP 13

 X6  X6

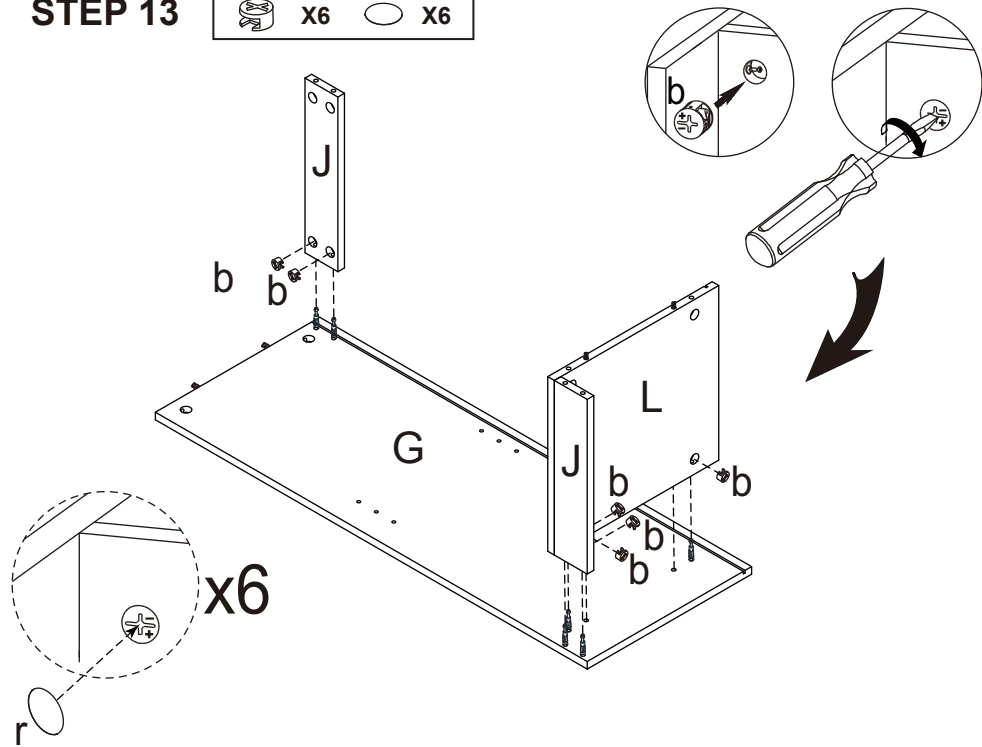

STEP 14

 X6  X2

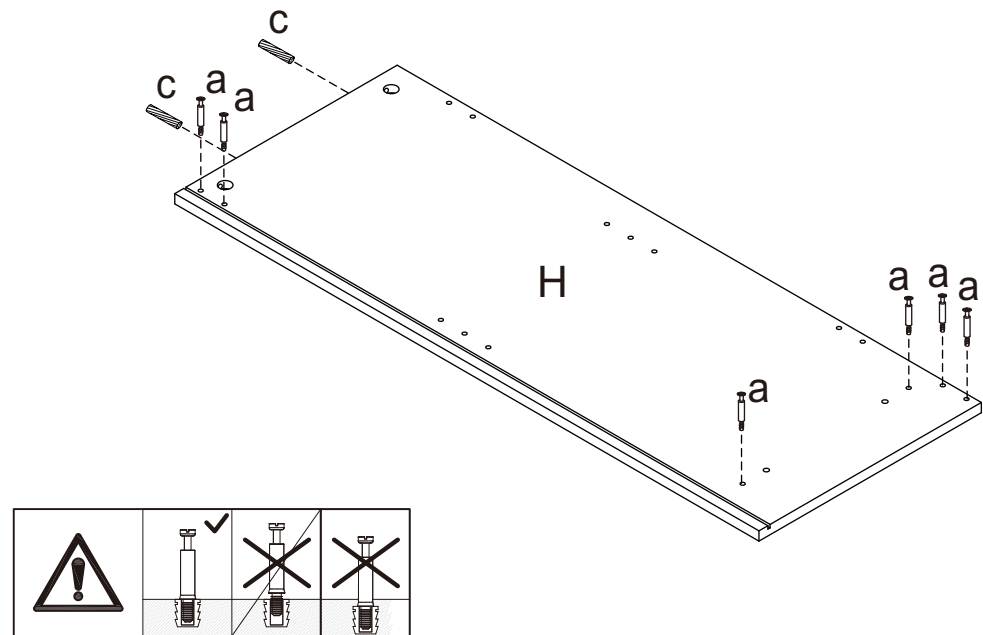

STEP 15

 X6  X6

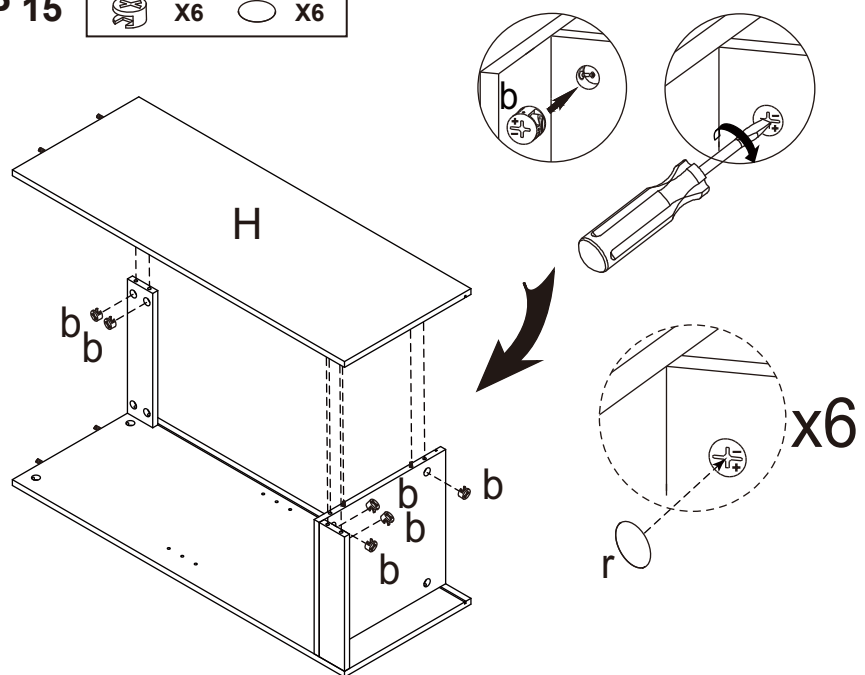

STEP 16

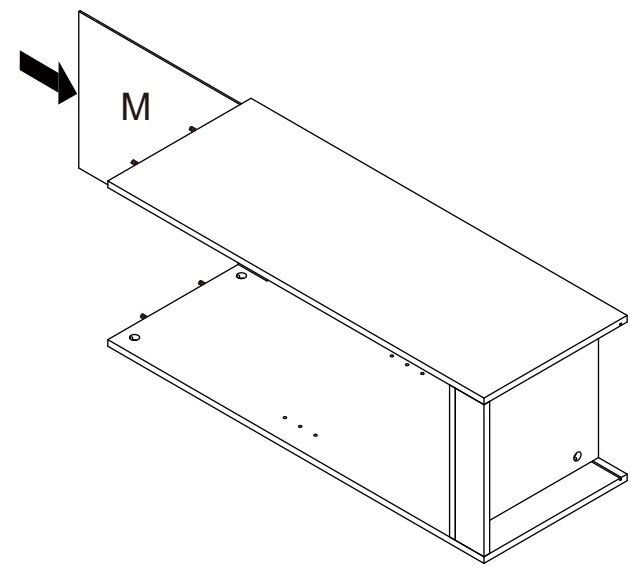

STEP 17

 X4  X4

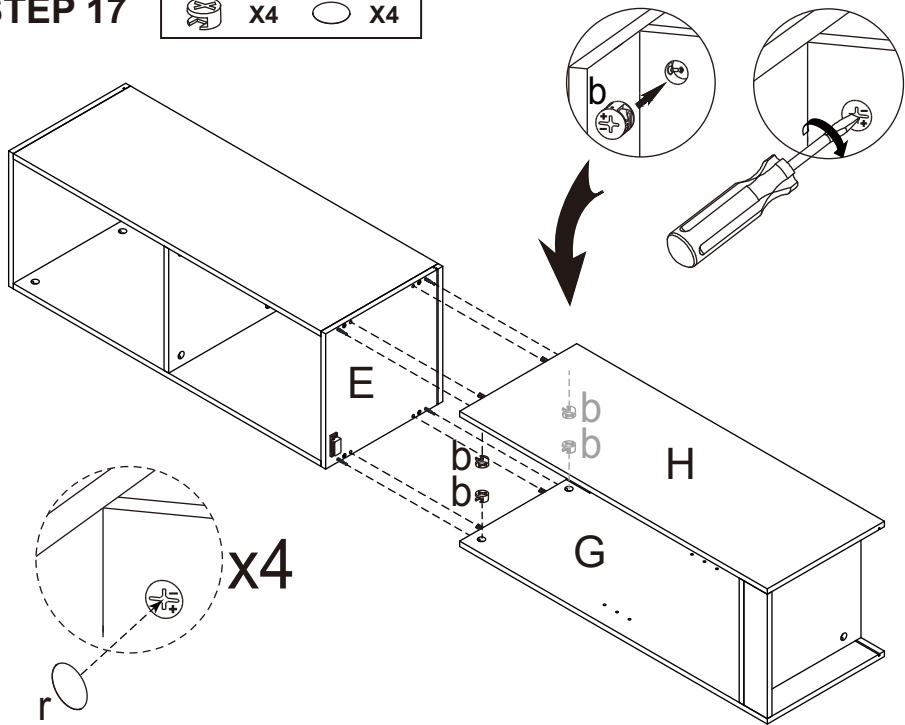

STEP 18

 X12  X12

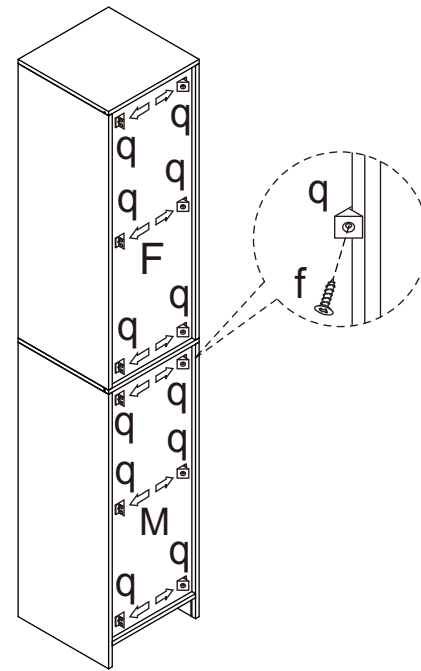

STEP 19

 X1  X1  X1  X1

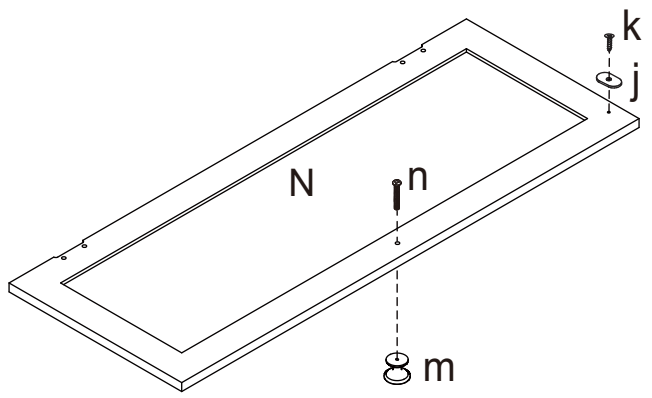

STEP 20

 X8  X2

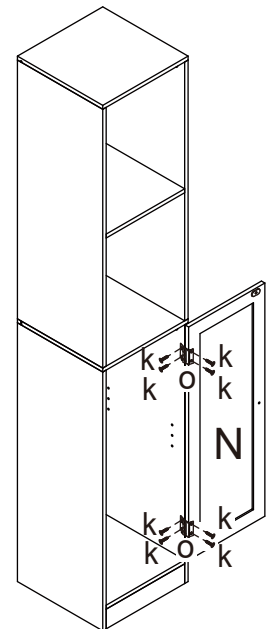

STEP 21

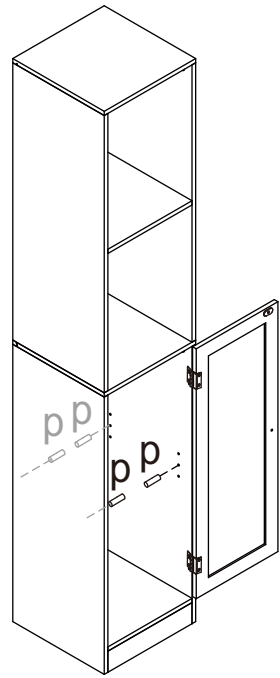
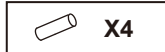

STEP 22

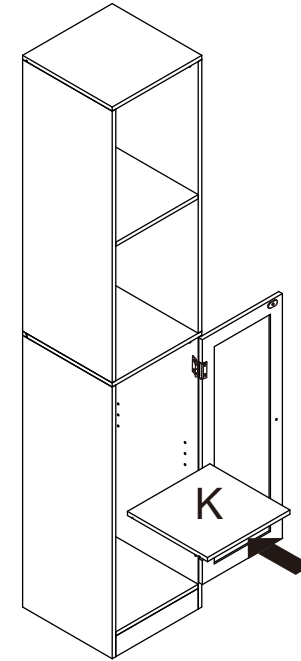

STEP 23



USER INSTRUCTION FOR WALL FIXINGS:
IT IS STRONGLY RECOMMENDED THAT THIS PRODUCT IS PERMANENTLY FIXED TO THE WALL. PLEASE SEEK PROFESSIONAL ADVICE IF YOU ARE IN DOUBT OF WHAT FIXING DEVICE TO USE. REGULARLY CHECK THAT WALL FIXING ARE SECURELY MAINTAINED. FOR YOUR SAFETY WHEN ATTACHING THE ANCHOR FIXINGS, PLEASE NOTE THE FOLLOWING: CHECK ANY ELECTRICAL WIRES OR PLUMBING INSIDE THE WALL BEFORE DRILLING ANY HOLES (IF YOU ARE UNSURE PLEASE SEEK PROFESSIONAL ADVICE FROM A QUALIFIED TRADESPERSON)

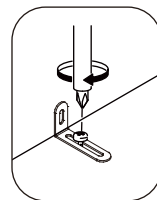
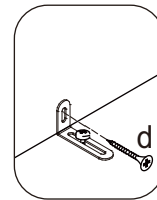
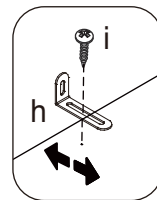
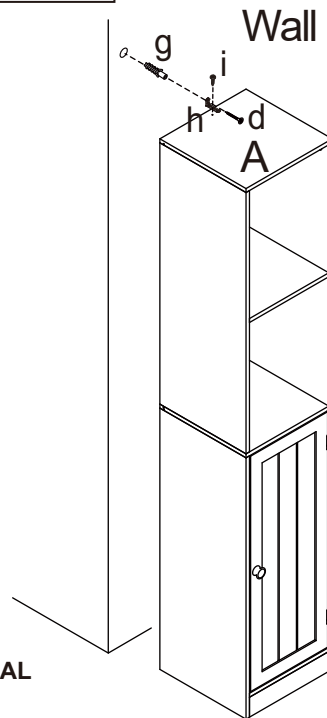

STEP 24

