

anko

Build Your Own Solar Chopper

- > integrates technology and handcrafts
- > adjustable solar panel
- > perfect to play under sunlight
- > easy to assemble, no glue or tools needed
- > battery free

8+
years

19
PIECES

STEM
SCIENCE
TECHNOLOGY
ENGINEERING
MATHS



SOLAR CHOPPER

Convert sunlight into electricity! See the chopper powered up by the sun!

Components

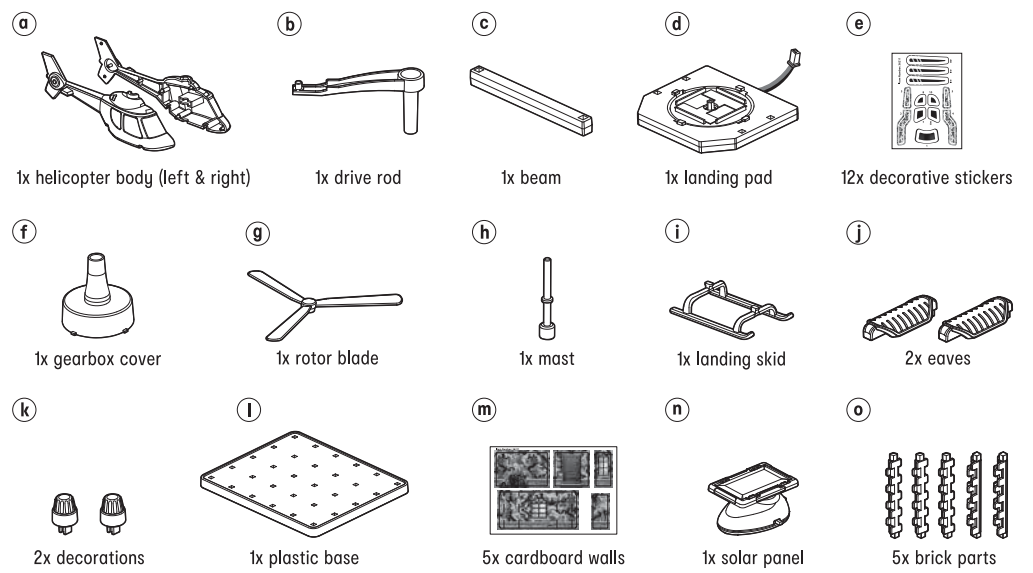

Educational Hints

Solar energy

The sunlight we see everyday carries energy. If you stand under the sun for a while, you can feel the heat carried by sunlight. The sun shines and provides warmth and heat to us. It is also an energy provider to form wind, to support plant growth, to provide warm and hot temperatures....etc. This light energy from the sun is called "solar energy" as a general term.

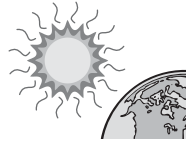

Why solar energy is said to be environmentally friendly:

As a power source, sunlight does not create pollutants. Solar energy which comes from the sun is an ever continuous power source. It will not exhaust and is therefore a kind of "renewable" energy. In generating electricity, unlike a traditional power plant, solar power is more environmentally friendly because it will not produce pollution. To convert sunlight into electricity directly, a solar panel is required:

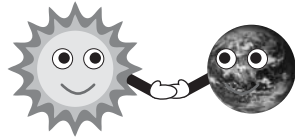

Structure of a solar panel

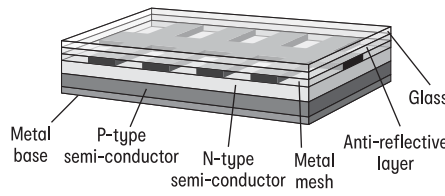

A solar panel is a device which can convert sunlight into electricity. The key components are layers of semi-conductors to form a solar cell. When light falls on a specific arrangement of semi-conducting material, some photons of sunlight will "kick" electrons to flow and form currents. Then electricity is created. This way light energy is converted to electrical energy. No pollutant is created in this process. As technology advances, different combinations of semi-conducting materials are created, which have different efficiency and costs. Therefore we can see more and more solar power products in our daily appliances. Some examples are:



Have you ever wondered if solar power to generate electricity is that good, why is it not used everywhere?

The reason is that solar cells are costly compared to the electricity that they can produce. The cost-effectiveness issue is a major concern for many companies. Therefore people still stick to a traditional power plant. Maybe as technology advances, we will see lots more devices using solar energy!

PRODUCT MAY VARY SLIGHTLY FROM IMAGES SHOWN. PLEASE KEEP PACKAGING FOR FUTURE REFERENCE.

WARNING: CONTAINS LEAD WITH FUNCTIONAL SHARP POINT.

WARNING: OVERHEATING HAZARDS. DO NOT TOUCH THE SOLAR PANEL.

WARNING: CHOKING HAZARD - SMALL PARTS. NOT SUITABLE FOR CHILDREN UNDER 3 YEARS.

WARNING: FOR SAFETY REASONS, REMOVE ALL TAGS, LABELS AND PLASTIC FASTENERS BEFORE GIVING THIS TOY TO YOUR CHILD.

WARNING: HAIR ENTANGLEMENT MAY OCCUR IF THE CHILD'S HEAD IS TOO CLOSE TO THE MOTORIZED UNIT OF THIS TOY. ADULT SUPERVISION AND ASSISTANCE IS REQUIRED.

FOR BEST RESULTS USE OUTSIDE IN DIRECT SUNLIGHT. THIS PRODUCT WILL NOT WORK IN CLOUDY LOCATIONS OR UNDER FLUORESCENT LIGHTS. PRODUCT MAY VARY SLIGHTLY FROM IMAGE SHOWN. PLEASE KEEP PACKAGING FOR FUTURE REFERENCE.

If at any time in the future you should need to dispose of this product please note that waste electrical products should not be disposed of with household waste. Please recycle where facilities exist. Check with your local authority or retailer for recycling advice. (Waste Electrical and Electronic Equipment Directive)

43-148-684

MADE IN CHINA

FOR AU / NZ: IMPORTED FOR KMART STORES IN AUSTRALIA AND NEW ZEALAND.

How to Assemble

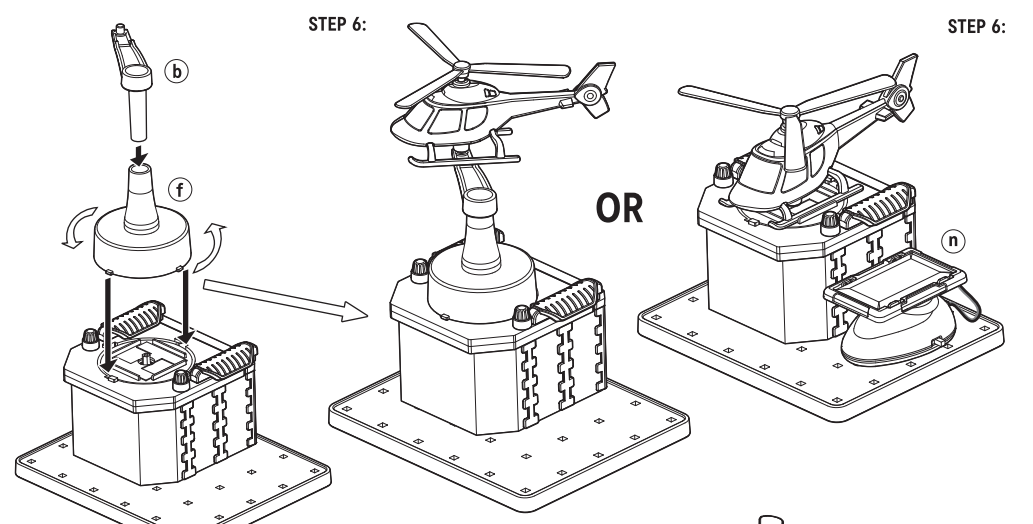
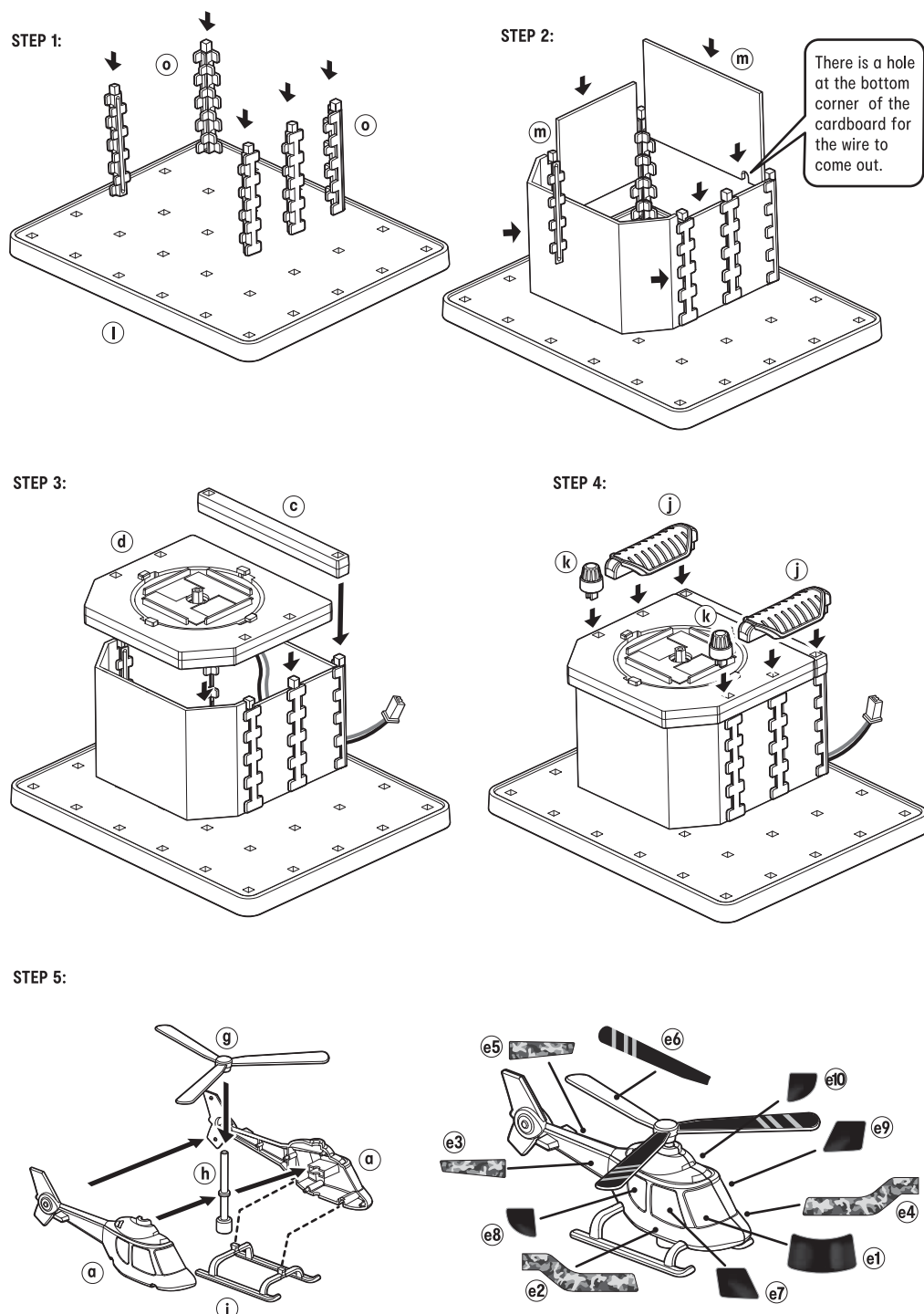

How to Play

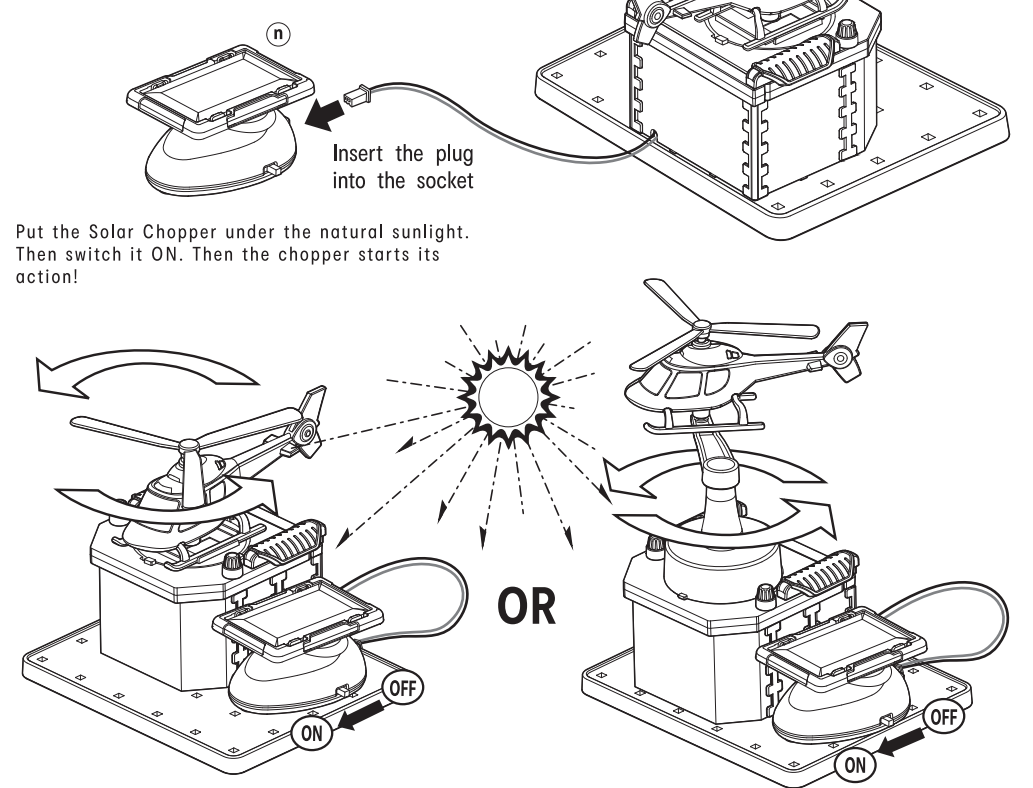

Suggestion
If it is a sunny day, you can place your Solar Chopper on your windowsill and watch it spin!