









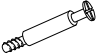

Assembly Instructions

43150519 HAVEN HALL UNIT OO

CARE INSTRUCTIONS: WIPE CLEAN WITH A SOFT CLOTH. NEVER USE SCOURERS, ABRASIVES OR CHEMICAL SOLVENTS. KEEP AWAY FROM MOISTURE AND DIRECT SUNLIGHT. STORE IN A DRY PLACE FOR INDOOR USE ONLY.

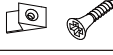
WARNING: DO NOT STAND, SIT OR LEAN ON THE UNIT. DO NOT USE THIS UNIT AS A STEP LADDER. ENSURE THIS UNIT IS USED ONLY ON A FLAT SURFACE. DO NOT USE THIS UNIT UNLESS ALL BOLTS AND SCREWS ARE FIRMLY SECURED. DO NOT PLACE HOT OBJECTS SUCH AS COFFEE CUPS DIRECTLY ON THE SURFACE OF THIS FURNITURE ITEM. THIS ITEM IS FOR STORAGE PURPOSE ONLY. CONTAINS SMALL PARTS. IT IS TO BE ASSEMBLED BY AN ADULT. FAILURE TO FOLLOW THESE WARNINGS COULD RESULT IN SERIOUS INJURY.

MAXIMUM SAFE LOAD: TOP:25KGS,SMALL SHELF:5KGS/LAYER,BIG SHELF:10KGS/LAYER.

	a	M6x35	10pcs		g	M6x60	2pcs
	b	M15x9	10pcs		i	M4x12	2pcs
	c	M6x70	4pcs		j	M4x35	2pcs
	d	M6x30	28pcs		k	M3x14	4pcs
	e	M4x40	15pcs		l	Ø20	6pcs
	f	Ø10x10	6pcs				

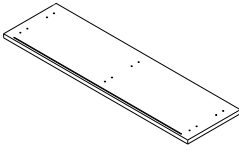
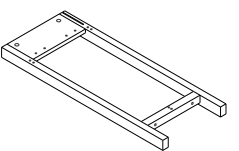
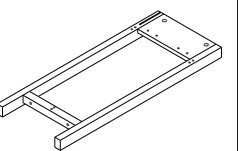
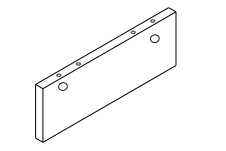
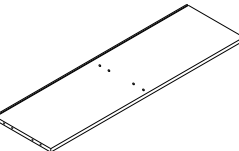
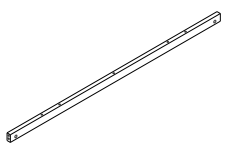
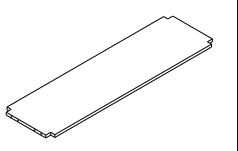
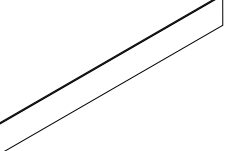
			
① 1pc	② 1pc	③ 1pc	④ 1pc
			
⑤ 1pc	⑥ 3pcs	⑦ 1pc	⑧ 1pc

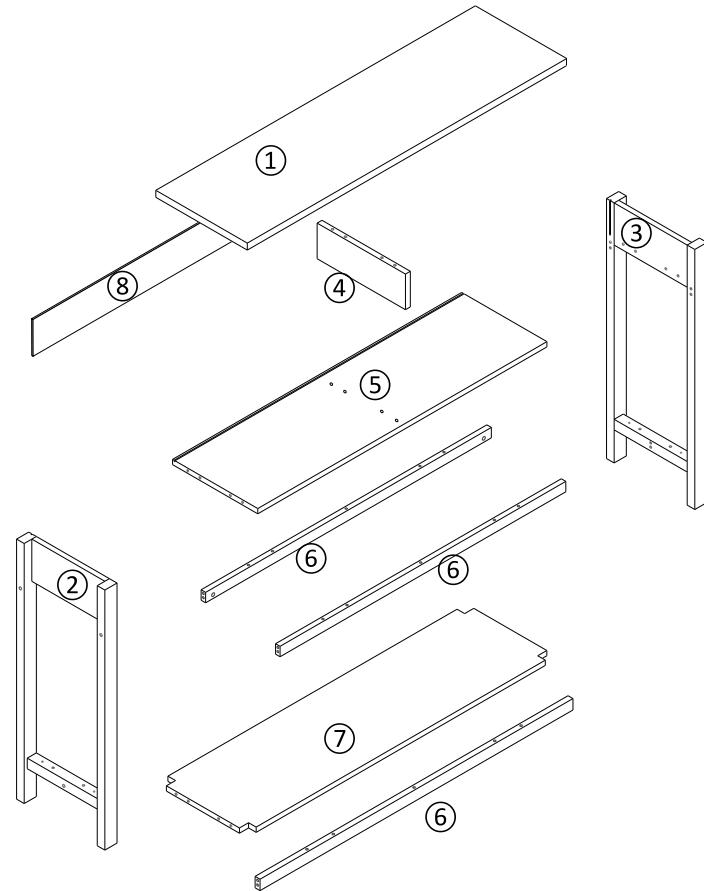

**Do not tighten the screws
Fully tighten screws after the final assembly steps**

step 1

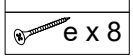
-  d x 6
-  e x 8

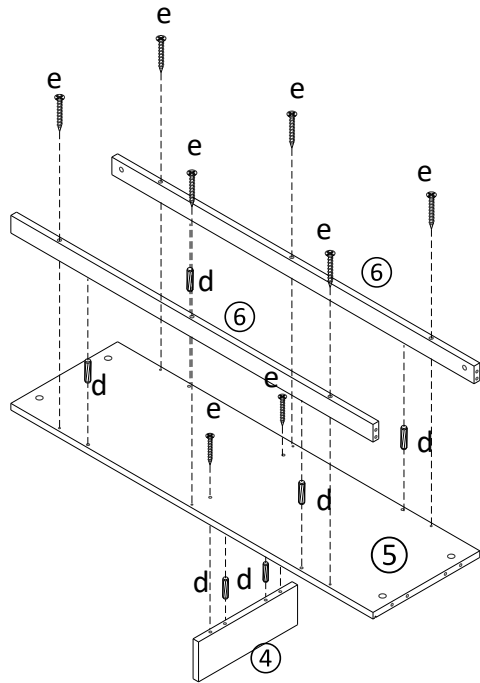

step 2

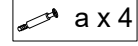
-  a x 4

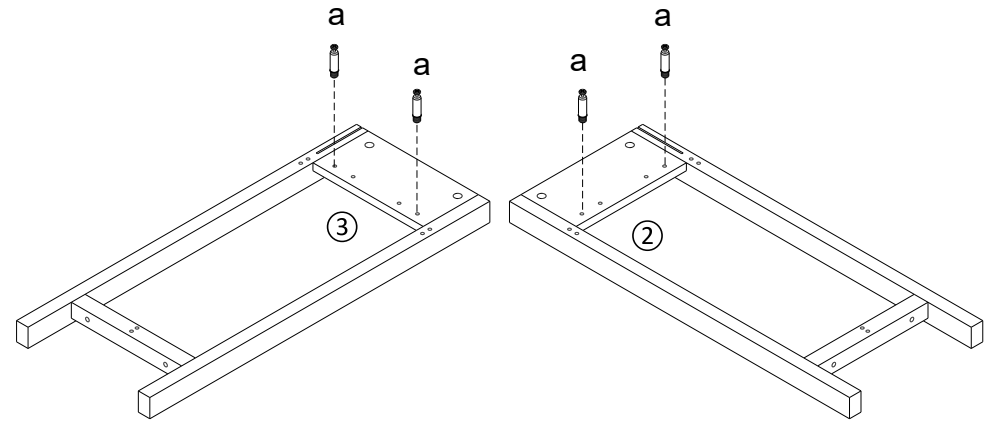

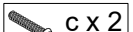
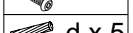
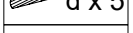
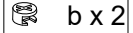
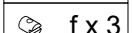

step 3

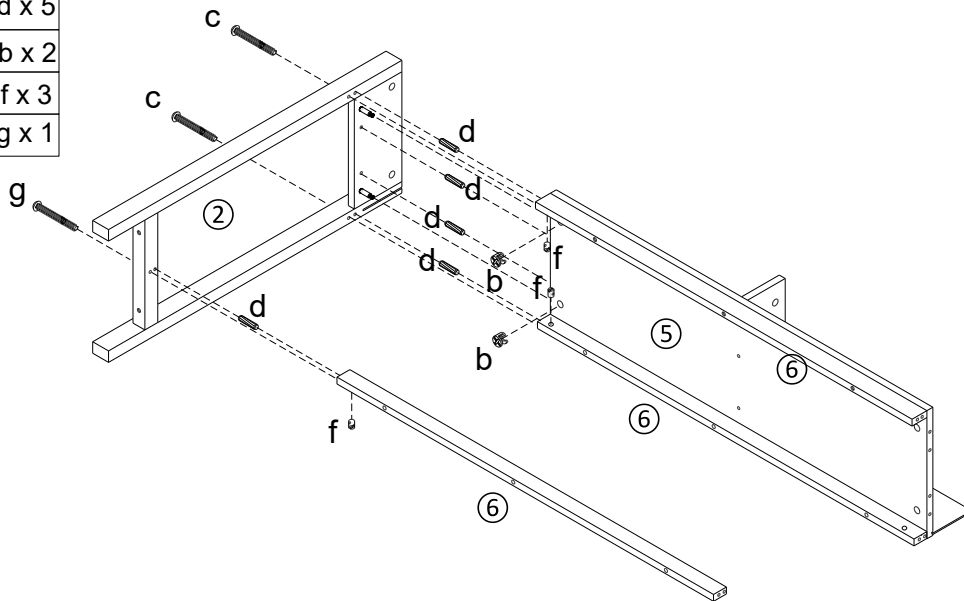
-  c x 2
-  d x 5
-  b x 2
-  f x 3
-  g x 1

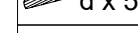
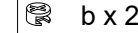
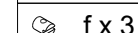

step 4

-  c x 2
-  d x 5
-  b x 2
-  f x 3
-  g x 1

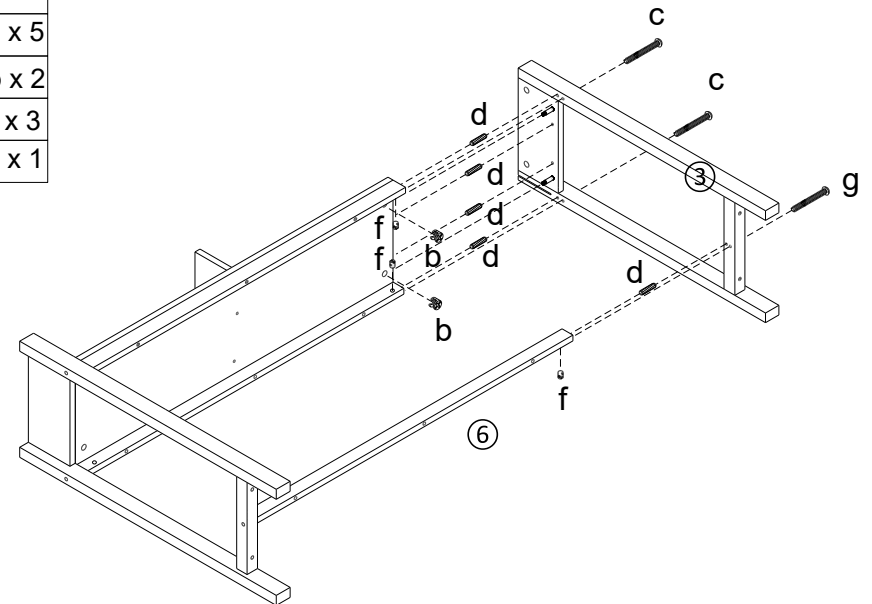

step 5

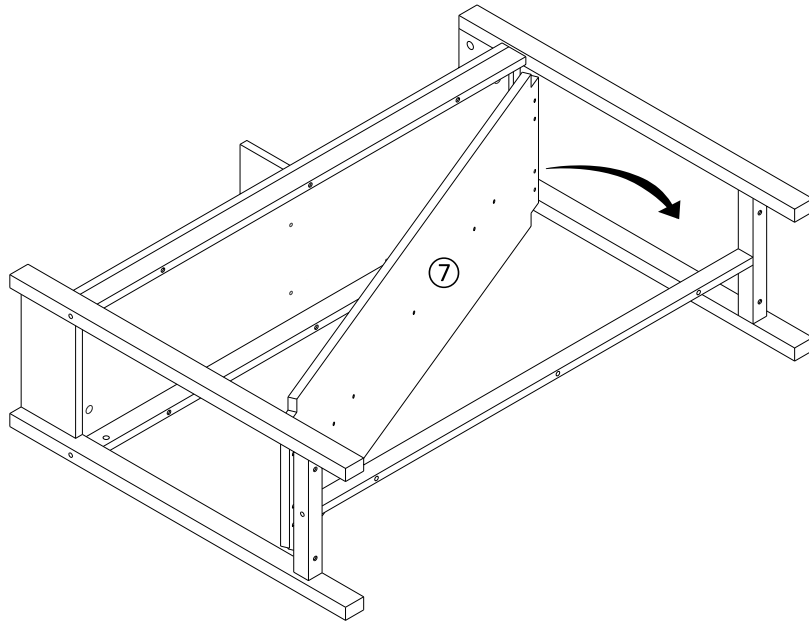

step 6

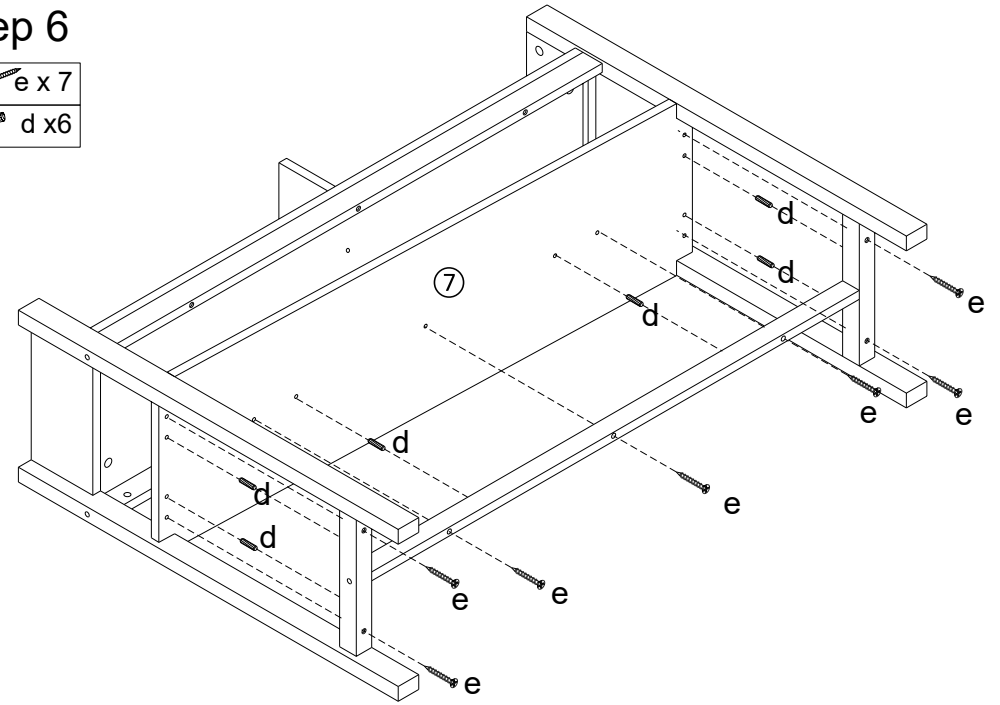
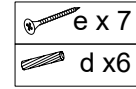

step 7

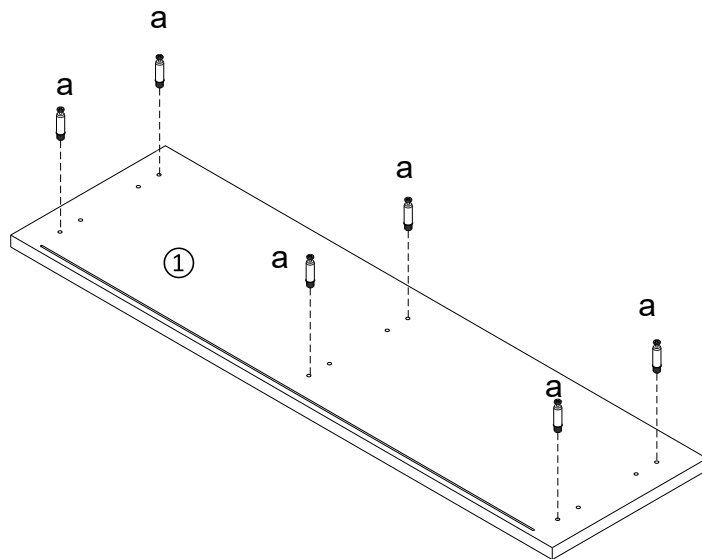
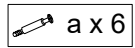

step 8

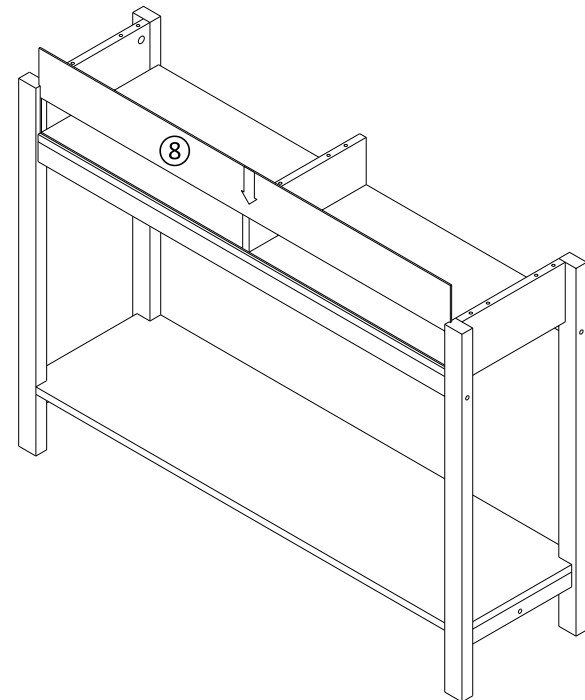

step 9

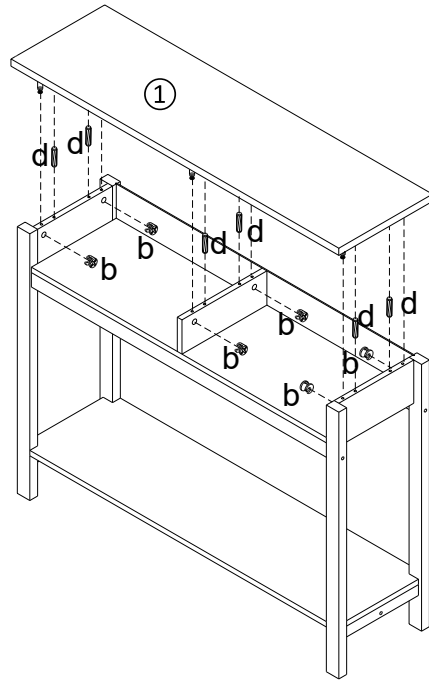
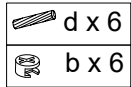

step 10

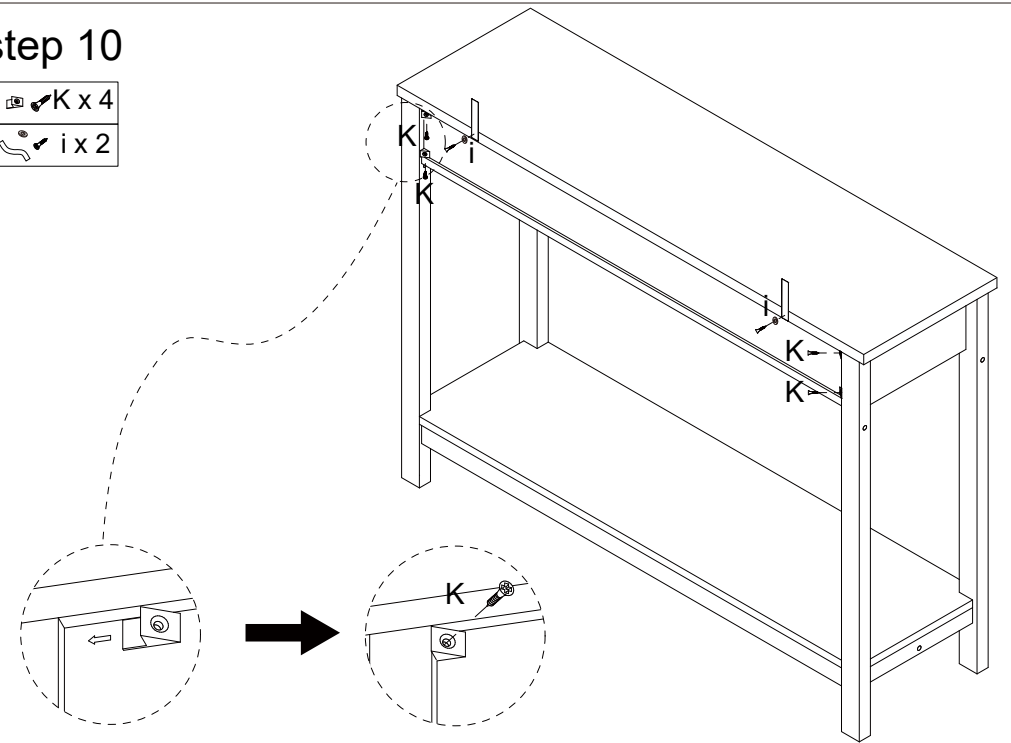

step 10

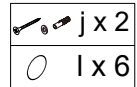

USER INSTRUCTION FOR WALL ANCHOR:
IT IS STRONGLY RECOMMENDED THAT THIS PRODUCT IS PERMANENTLY FIXED TO THE WALL. PLEASE SEEK PROFESSIONAL ADVICE IF YOU ARE IN DOUBT OF WHAT FIXING DEVICE TO USE. REGULARLY CHECK THAT ANCHORS ARE SECURELY MAINTAINED. CAUTION: FOR YOUR SAFETY WHEN ATTACHING THE ANCHOR FIXINGS, PLEASE NOTE THE FOLLOWING: CHECK ANY ELECTRICAL WIRES OR PLUMBING INSIDE THE WALL BEFORE DRILLING ANY HOLES (IF YOU ARE UNSURE PLEASE SEEK PROFESSIONAL ADVICE FROM A QUALIFIED TRADESPERSON)

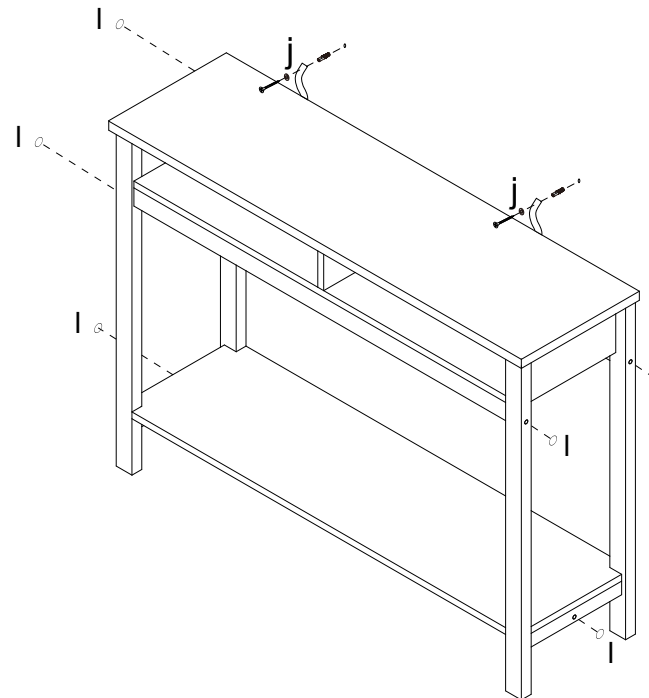

WARNING: PLEASE SECURE YOUR FURNITURE WITH THE SUPPLIED WALL FIXING. SCAN THE CODE FOR



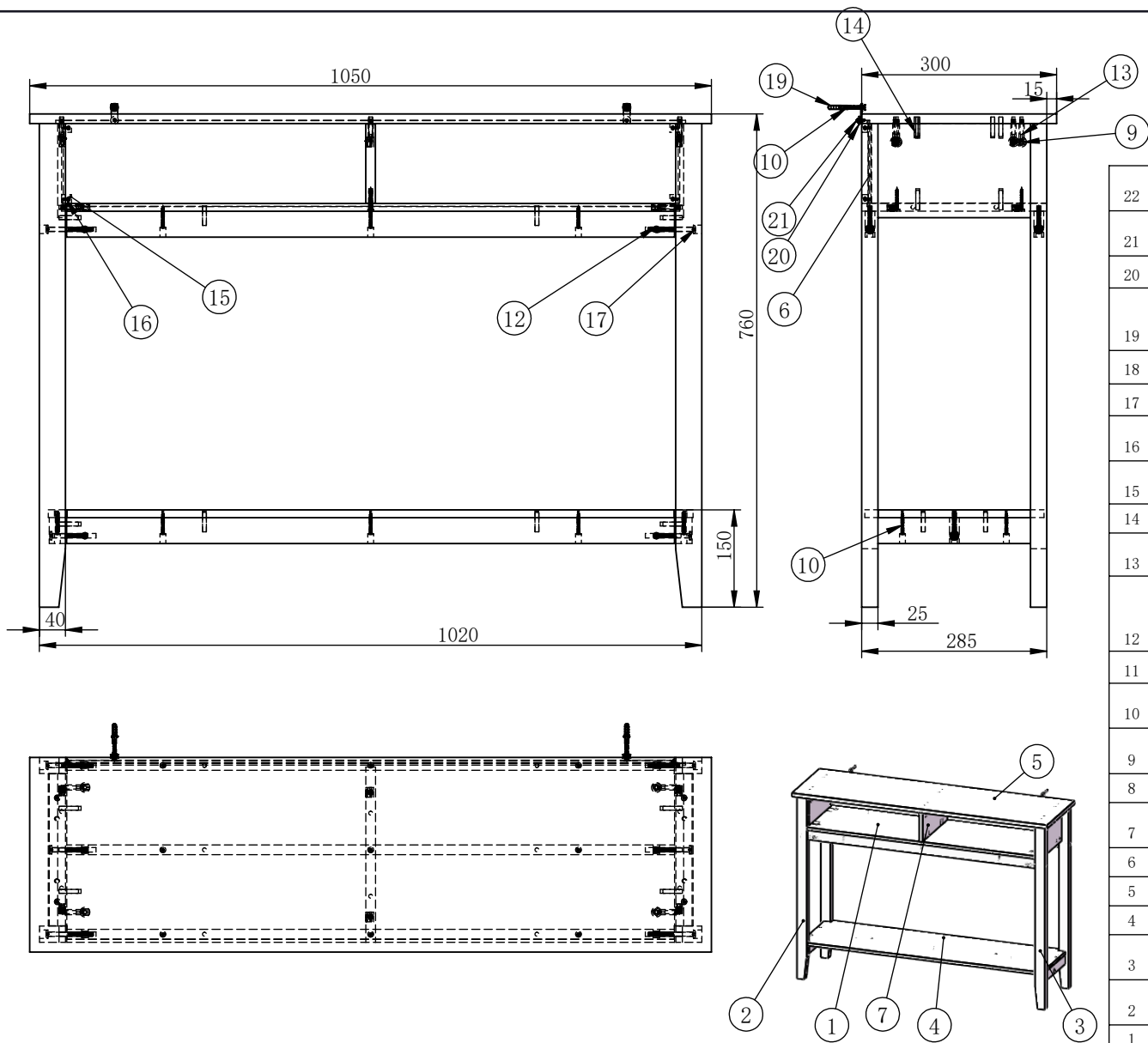

22	孔贴	Hole stick	Ø20	paper	6	
21	盘头自攻钉4x12	tapping screws	ST4x12	ST	2	white zinc
20	垫圈D12Xd4.5x1	washers	d6.5xD13x1.0	ST	4	white zinc
19	塑料膨胀管	Plastic expansion tube	Ø6x30	Plastic	2	white
18	防倒带	belt		nylon	2	white zinc
17	倒角平头螺丝M6X70	screw	M6*70	ST	4	white zinc
16	沉头自攻钉3x14	tapping screws	ST3x14	ST	4	white zinc
15	角码	Corner connector	15x13.5x9.5	HDPE	4	white
14	圆棒榫	Wood nog	6x30	Wood	28	
13	二合一螺杆	Two in one screw	ST6x35	ST	10	white zinc
12	M6锤仔横孔螺母	Hammer nut with horizontal hole	Ø10*10	ST	6	white zinc
11	倒角平头螺丝M6X60	screws	M6*60	ST	2	white zinc
10	沉头自攻钉4x40	tapping screws	ST4x40	ST	17	white zinc
9	二合一偏心轮	Eccentric wheel	Ø15x9	ST	10	white zinc
8	层板立水	Apron	936*40*15	MDF	3	Painting
7	中立板	Middle spacer	270*122*15	MDF	1	Painting
6	背板	Rear panel	947*132*2.5	MDF	1	Painting
5	顶板	Top plate	1050*300*15	MDF	1	Painting
4	底板	Base plate	993*276*12	MDF	1	Painting
3	右脚组合	Right Table leg	745*285*40	MDF	1	Painting
2	左脚组合	Left Table leg	745*285*40	MDF	1	Painting
1	层板	Laminate	936*285*12	MDF	1	Painting
NO.	零件名称	Spare parts	Spec	Material	QTY	Remark

名称	43150519			修正日期		核准
图号	-	核准				
零件编号	-	审核				
材质		校对				
单位	mm	绘图	shawn 2022/3/21			



优臣进出口贸易有限公司

地址:上海市普陀区金沙江路1977弄3号楼5楼
电话:+ 86 21 34240866, 51087768 分机 309