

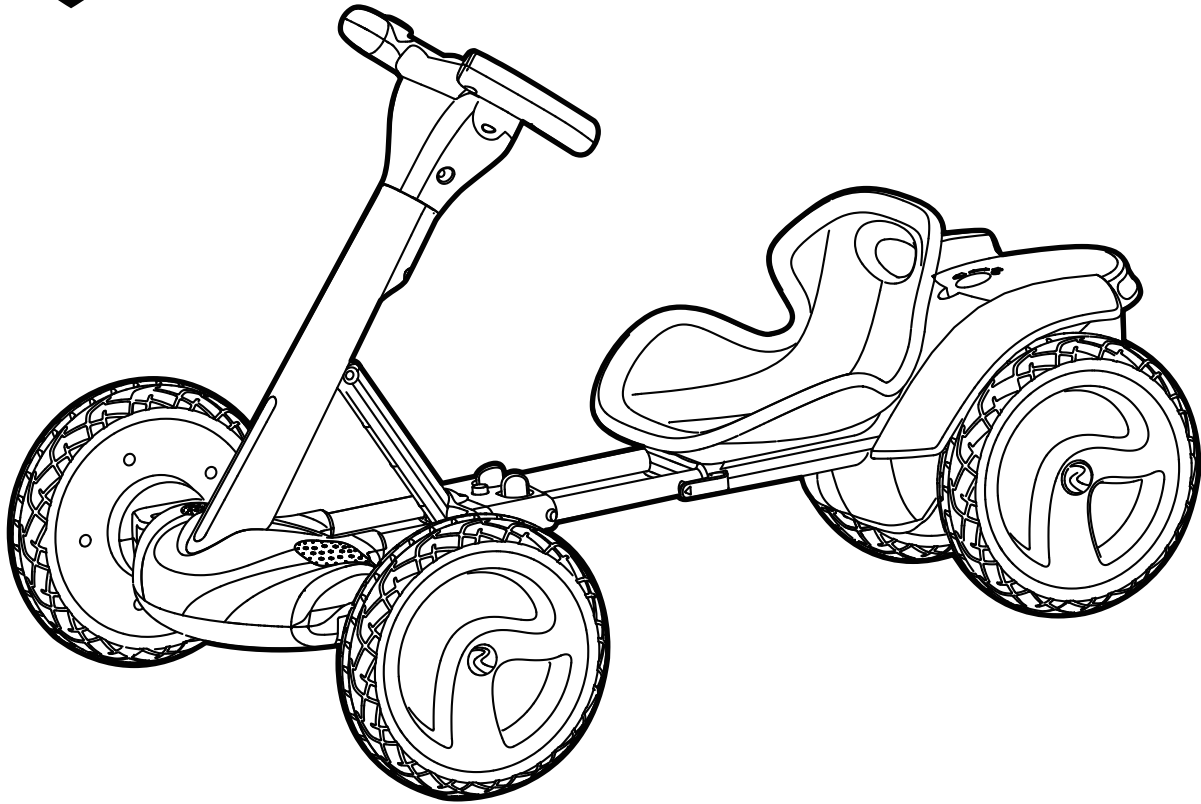

# ROLLPLAY

## FLEX KART



## Owner's Manual and Assembly Instructions

Model #: W405B, HUN0685, 43192847

Read and study the entire manual before assembly and operation. The vehicle must be assembled by an adult who has read and understood the instructions.

Made in China.

Styles and colors may vary. Prior to returning to the store, please contact Rollplay's Customer Service with questions. Visit us online at [www.rollplay.com](http://www.rollplay.com) for assistance and replacement parts.

**IMPORTANT:**  
**Save this manual with your sales receipt.**



If you are experiencing any difficulties with this product, please contact Hunter Products Customer Service at [www.electricrideon.com.au](http://www.electricrideon.com.au) or Toll Free Number 1800 224 094 for service assistance.

# Introduction

Thank you for purchasing this vehicle. We hope the rider enjoys it for years to come. Please read this instruction guide carefully before assembling and operating the vehicle. Please have your model number and serial number ready before calling. Please have proof of purchase.

Please contact Hunter Products Customer Service with any questions.

Hours: 9.00 AM - 5.00 PM (AEST), Monday - Friday

Web: [www.electricrideon.com.au](http://www.electricrideon.com.au)

Service Phone: 1800 224 094

Service email: [enquiries@hunterproducts.com.au](mailto:enquiries@hunterproducts.com.au)

## **Speci cations:**

BATTERY	6V 4AH
MOTOR	6V
AGES	2-5 Years
MAX WEIGHT	25 kg (55 lb)
PRODUCT SIZE	780 x 540 x 485 mm (30.7 x 21.3 x 19.1 in)
SPEED	Up to 3.2 km/h (2 MPH)
RECHARGE TIME	8-12 Hours
TYPICAL RUN TIME	1-2 Hours
CHARGER OUTPUT	DC 7.0V

# IMPORTANT!

**YOU MUST CHARGE THE BATTERY  
FOR 12 HOURS BEFORE FIRST USE!**

Charge the battery after each use.

Charge the battery at least once a month, even if the vehicle is not in use.

Email or call Customer Service if you need assistance or replacement parts.

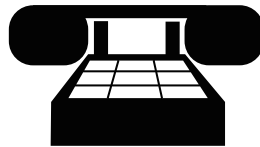

**QUESTIONS AND SERVICE  
PLEASE CALL: 1800 224 094  
email:enquiries@hunterproducts.com.au**

**Read this entire manual to ensure  
proper assembly and safe operation  
of the vehicle.**



## **WARNING: SAFE RIDING RULES**

After assembling any wheel to the axles, please check the gap between the screw thread and the collapsible, if the gap is too big, please add two or three washers inside the wheel, but after tightening the nut outside the wheel, please turn the wheel by your finger to check if the wheel can run smoothly, this is very important, because if the wheel can run smoothly, it is ok, but if the nut press the wheel and the wheel can not run smoothly, it maybe produce heavy noise or some parts break easily. Then you need to decrease one or two washers to make sure the wheel can run smoothly.

Safety .....	6
Parts .....	8
Charging Instructions .....	9
Unfolding the Frame .....	10
Installing the Steering Wheel .....	11
Attaching the Seat .....	12
Operating Instructions .....	13
Folding Instruction .....	14
Maintenance .....	15
General Care .....	16
Troubleshooting Guide .....	17
FCC Information .....	19
Service and Repairs .....	20
Warranty .....	21



## WARNING: SAFE RIDING RULES

- Instruction sheet and packaging must be retained since it contains important information.
- The user must follow all safety rules and guidelines, or serious injury or death may occur to the user.
- Always use common sense and safe practices when using the vehicle. User must be at least 24 months old and weigh no more than 25kg (55 lbs.).
- This product contains small parts that are for adult assembly only. Keep small children away when assembling. Remove and dispose of all protective material and plastic bags before assembling.
- **Riders must always wear a fitted helmet.**
- Only sit on the seat in the vehicle.
- Do not allow more than one rider.
- Do not overload the vehicle. Do not remove the weight restriction decals.
- Do not pull the vehicle with another vehicle or similar device.
- Keep body parts such as hands, legs, hair and clothing away from moving parts. Moving parts can cause serious injury.
- Always wear shoes while in the vehicle.
- Do not operate near streets or motor vehicles.
- Do not operate near drop-offs such as steps, steep inclines or hills. Operate on relatively level ground.
- Do not operate near water, swimming pools or bodies of water.
- Do not operate in dangerous weather conditions such as rain or snow.
- **Do not operate near loose dirt, mud, sand or fine gravel.**
- **Do not operate near flammable vapors (gasoline, paint thinner, acetone, etc.).**
- Always operate the vehicle in a safe, secure environment with adult supervision.
- Remove batteries if product is to be left unused for a long time; Always replace the whole set of batteries at one time; Do not mix old and new batteries; Do not mix alkaline, standard (zinc-carbon) or rechargeable (nickel-cadmium) batteries.

### PREVENT INJURIES AND DEATHS:

**NEVER LEAVE CHILD UNATTENDED. ALWAYS** keep child in view when child is inside the vehicle. Direct adult supervision is **REQUIRED**.

**NEVER** use in roadways, near motor vehicles, on or near steep inclines or steps, swimming pools or other bodies of water.

**ALWAYS** wear shoes.

**ALWAYS** sit on the seat.

**RISK OF FIRE.** Do not bypass.



## WARNING: BATTERY SAFETY

- Battery posts, terminals and related accessories contain lead and lead components. DO NOT open the battery.



- Contact exposure to battery leakage (lead acid) may cause serious injury. Immediately contact your doctor if exposure occurs. If the chemical is on the skin, flush immediately with cool water for 15 minutes. If the chemical is swallowed immediately give the person water or milk. Do not give water or milk if the person is vomiting or has decreased alertness. Do not induce vomiting.

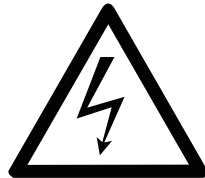

- Tampering or modifying the electric circuit system may cause shock, fire or explosion. It could permanently damage the system. Keep the charger housing closed to prevent exposed wiring, which may cause electric shock.
- IMPORTANT: Before using the vehicle for the first time, the battery must be charged for a full 24 hours (no more than 30 hours).



## WARNING: ADULT SUPERVISION REQUIRED

- Before using the vehicle, the rider must understand the vehicle controls and safety issues.
- It is the responsibility of the adult to educate the child and determine if the child is capable of understanding the vehicle controls.
- An adult must ALWAYS directly supervise the use of this vehicle.
- NEVER leave a child unsupervised in the vehicle.

# 8 Parts

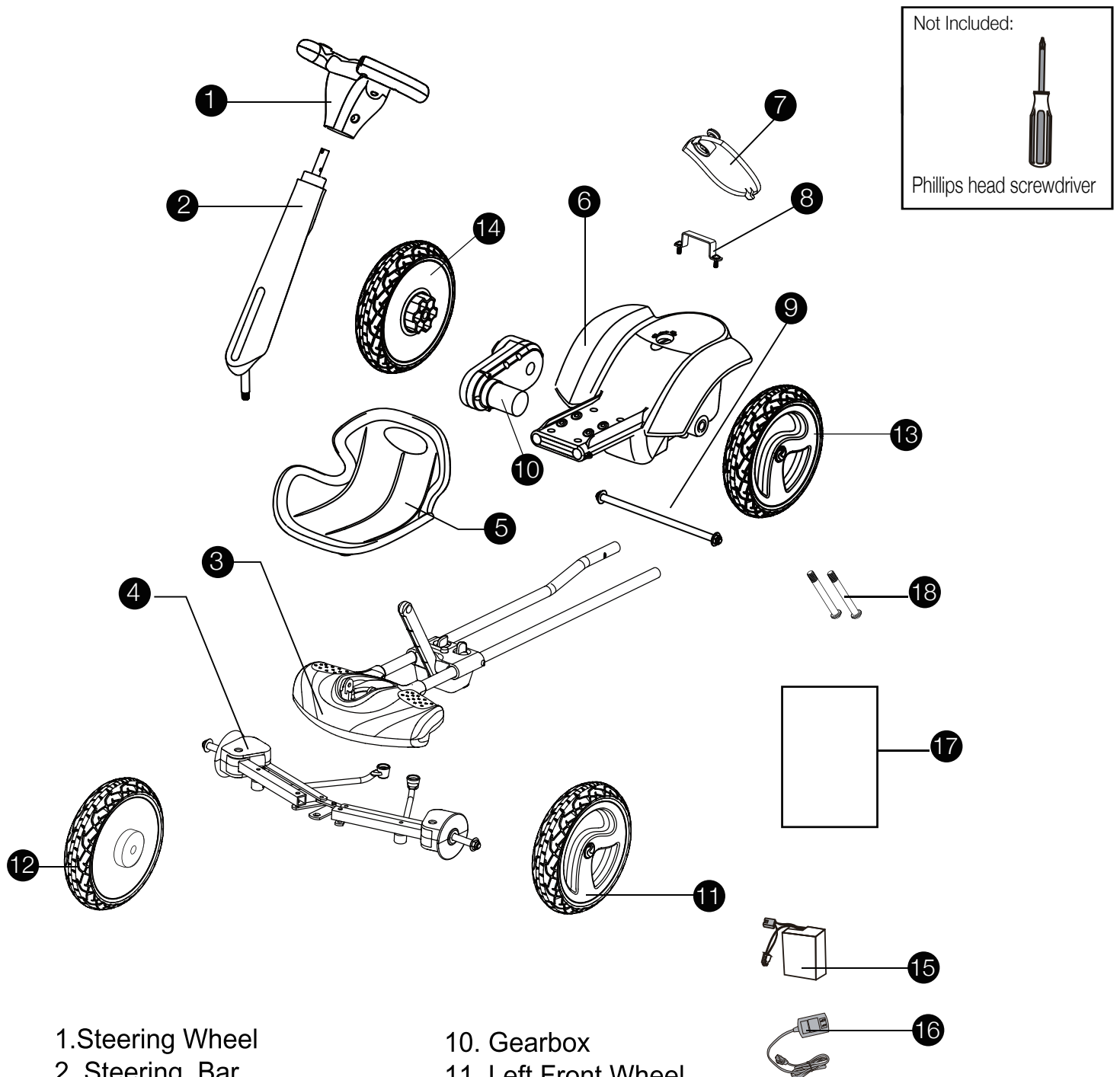

Not Included:  
  
 Phillips head screwdriver

1. Steering Wheel

2. Steering Bar

3. Frame

4. Front Axle

5. Seat

6. Vehicle Body

7. Battery Compartment Cover

8. Battery Clamp

9. Rear Axle

10. Gearbox

11. Left Front Wheel

12. Right Front Wheel

13. Left Rear Wheel

14. Right Rear Wheel

15. Battery

16. Charger

17. Manual

18. Screws (M6\*38) x 2

(located in the seat's polybag)

NOTE: Parts 2-4, 6-14 are for reference only and are packed already assembled.



## YOU MUST CHARGE THE BATTERY FOR 24 HOURS BEFORE FIRST USE!

**ONLY AN ADULT SHOULD HANDLE THE BATTERY AND CHARGER.**

### To Charge the Battery:

1. Ensure the FLEX Kart is stopped and turned off.
2. Locate the cover in the rear of the car. Using a coin or screwdriver turn the cover lock to the unlocked position and remove the cover.
3. Unplug the red battery connector (A) from the red engine connector (B).
4. Connect the red battery connector (A) to the red battery charger connector (C) and plug (D) into a 240 V outlet.

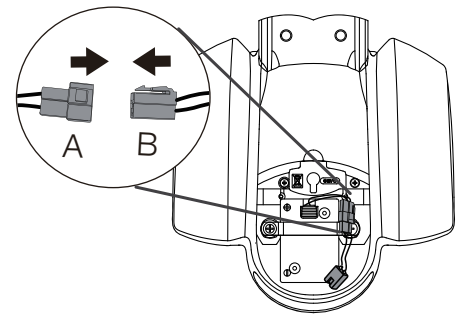
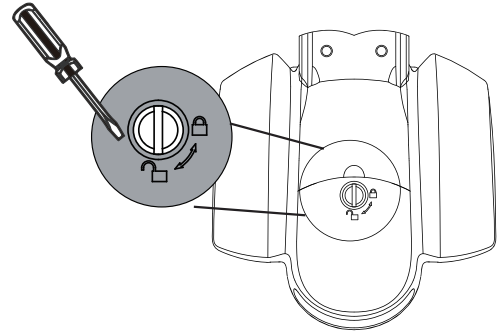

### To Reconnect the Battery:

1. Unplug the battery charger (D) from the outlet.
2. Unplug the red battery connector (A).
3. Reconnect the red battery connector (A) to the red engine connector (B).
4. Replace the seat and lock in place.

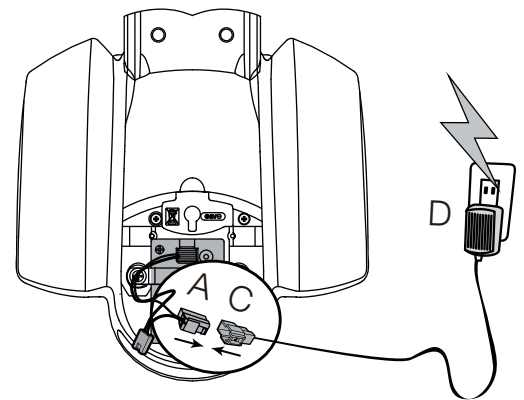

Note: It is not necessary to remove the battery for charging. However, if the battery does not reach the outlet, it can be removed for charging. Use a screwdriver to release the battery clamp and disconnect the red battery connector from the red engine connector to remove the battery.

# 10 Unfolding the Frame

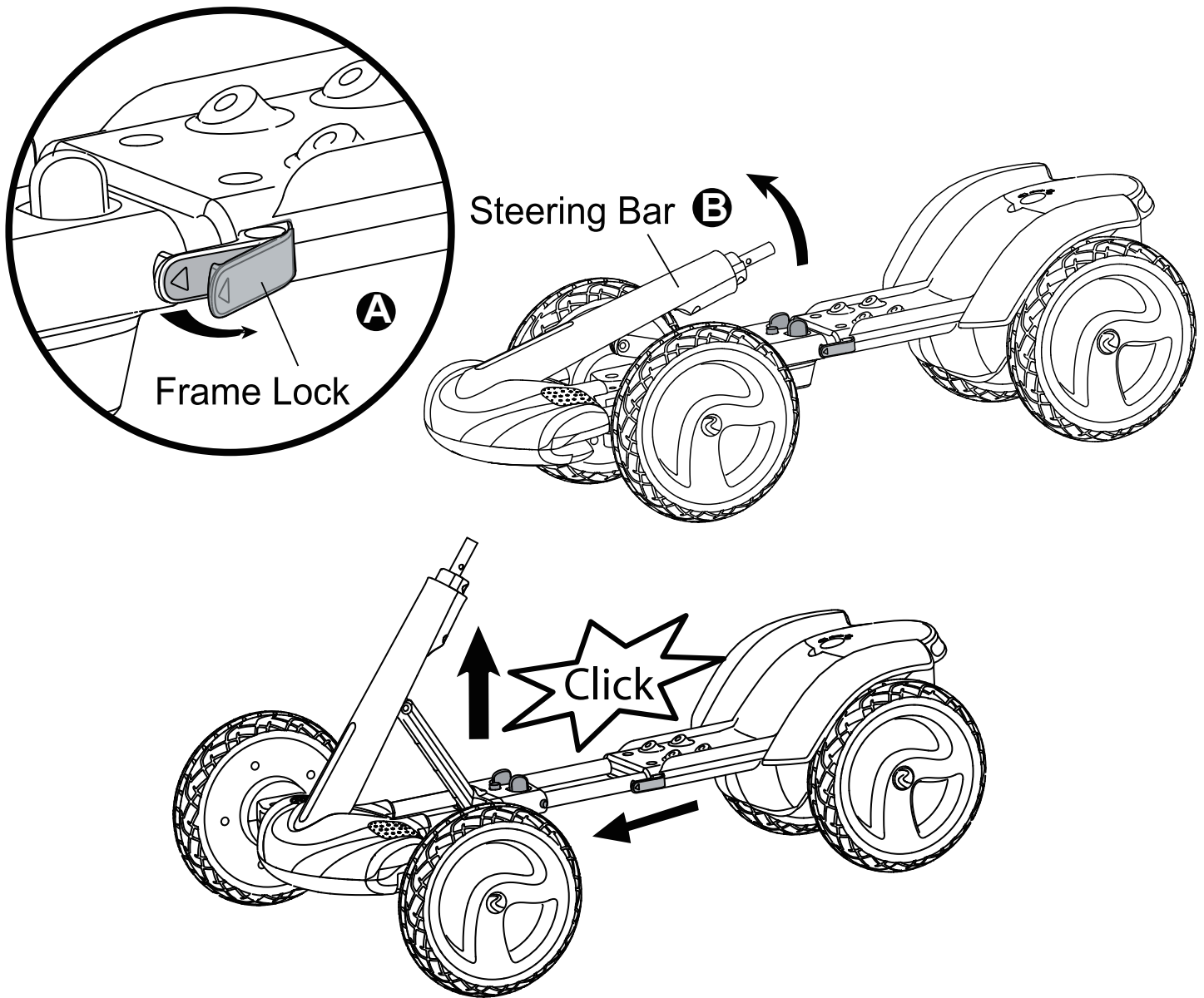

After taking the vehicle out of the package,

- 1) Release the Frame Lock by pulling it outward from the vehicle (Fig A).
- 2) While holding the Frame Lock in the released position, pull upwards on the Steering Bar towards the front of the vehicle until it clicks into place (Fig B).
- 3) Let go of the Frame Lock.

**Tip:**

To make the Frame Lock easier to release, press down on the steering bar and then try again.

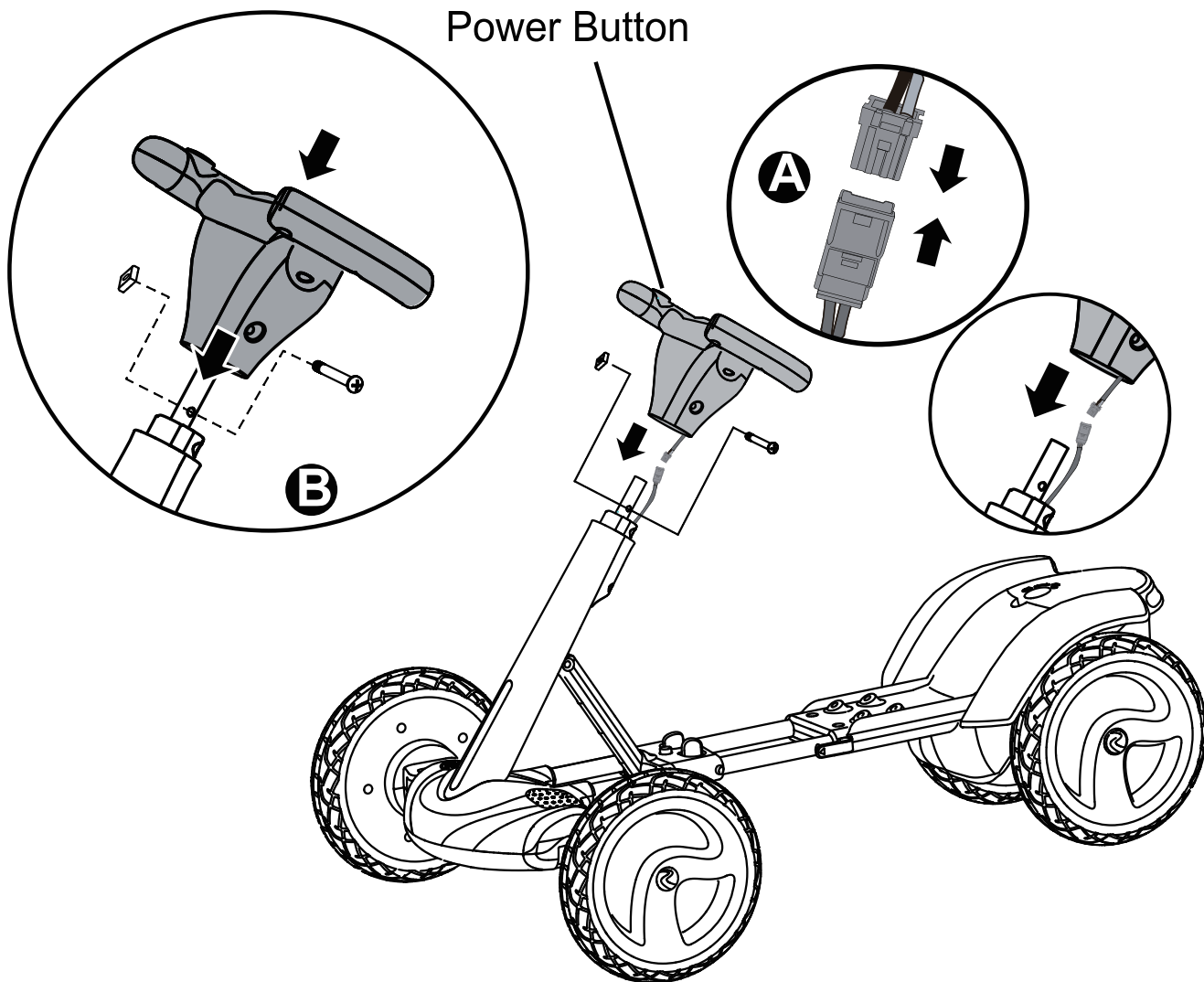

- 1). Remove the screw (M5\*47) from the Steering Wheel.
- 2). Plug the steering wheel wire into the steering bar wire. (Fig A)
- 3). Place the steering wheel onto the top of the steering bar, match the screw holes of the steering wheel and the steering bar. (Note: Gently tuck the wires completely into the steering bar, to avoid damage to the wires. )
- 4). Insert the screw (M5\*47) into the hole and fasten with the nut to secure. (Fig B)

## 12 Attaching the Seat

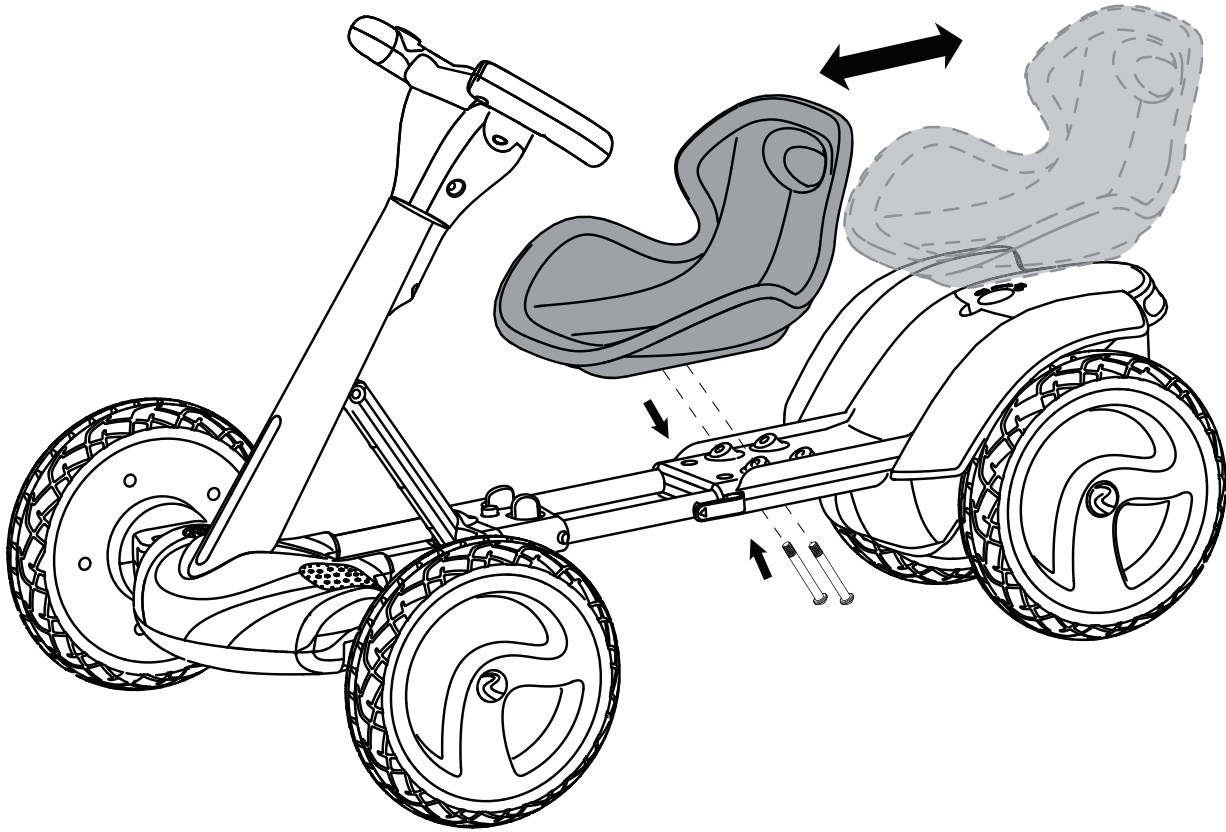

- 1). Remove screws (M6\*38) from the the seat's polybag.
- 2). Align the two holes on the Seat over the holes on the vehicle body to the desired position. Insert the screws through the holes on the seat and the frame, tighten with a Phillips head screwdriver.

**Note:** There are two length options. We suggest moving the seat back to the second position, once your child outgrows the shorter length.

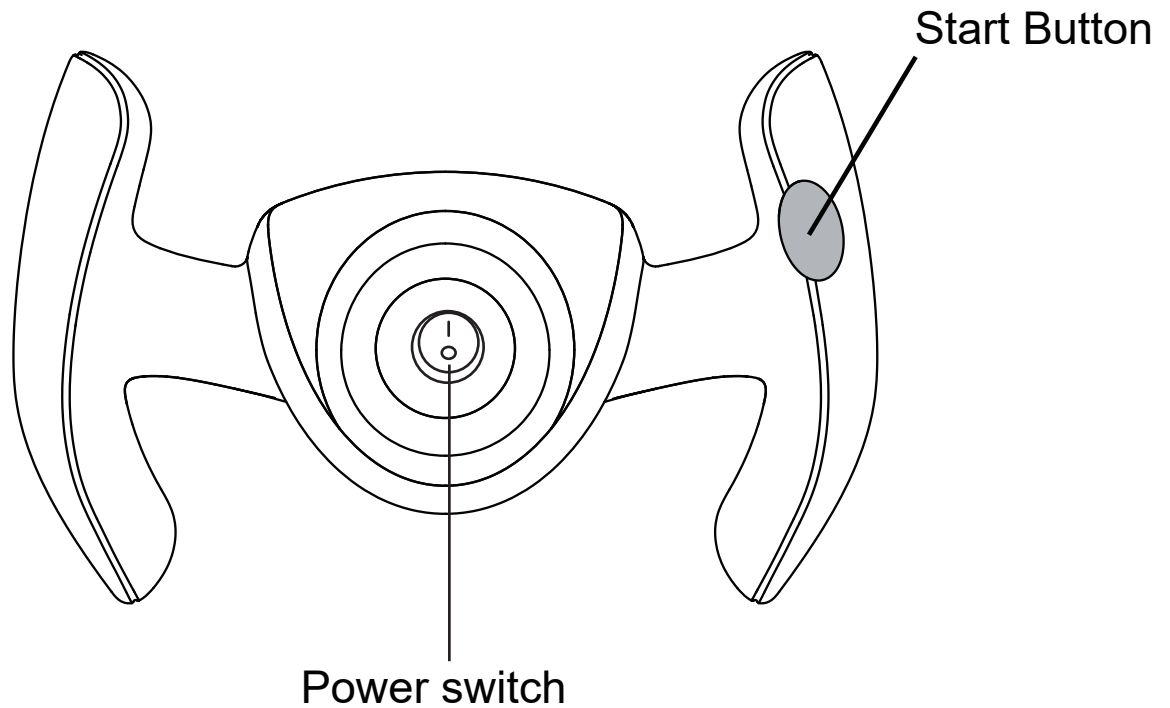

Turn on the power switch, Press the Start Button at the right of the Steering Wheel handle (Do not release) to control the left and right steering or forward riding through the steering wheel.

# 14 Folding Instructions

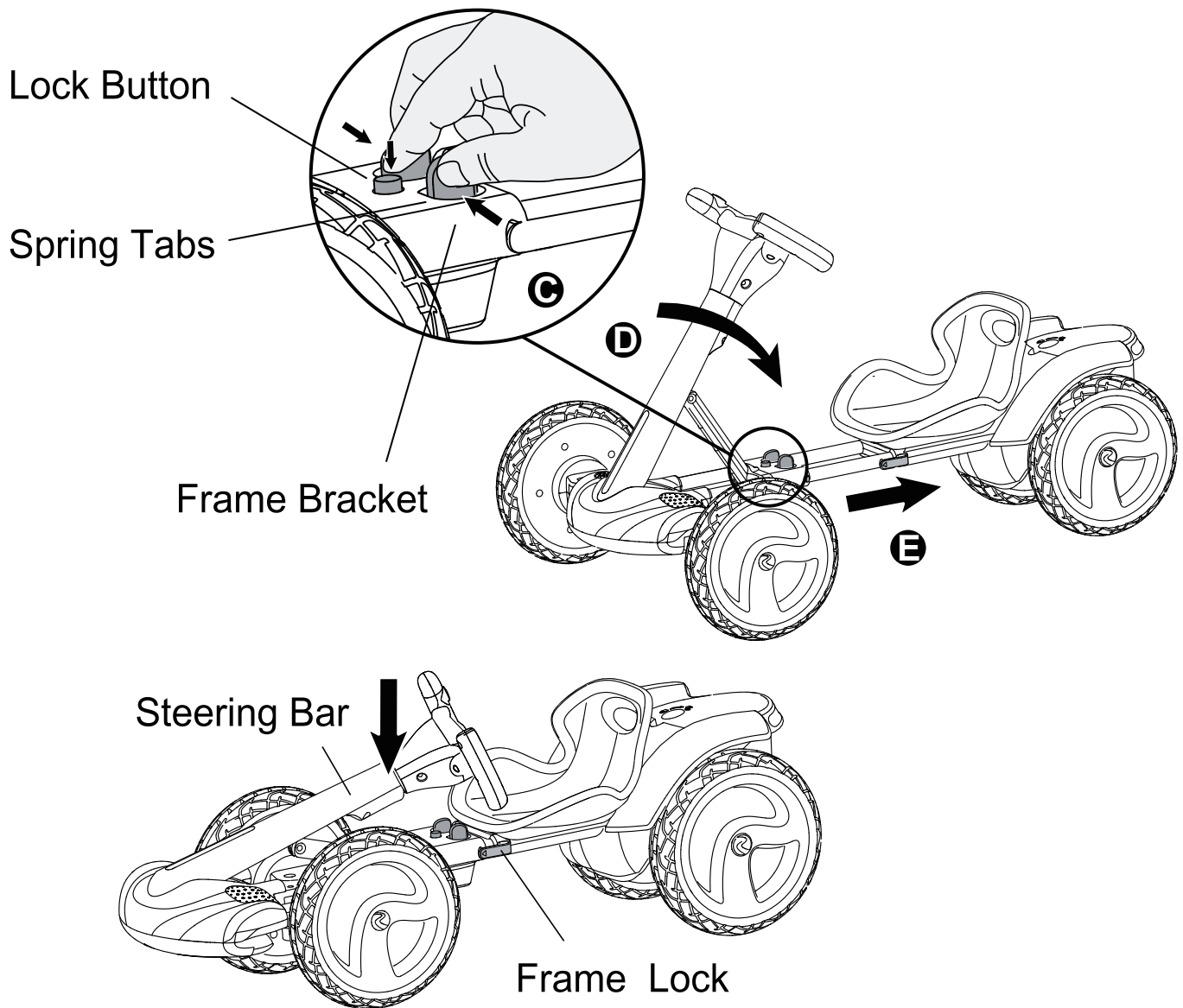

- 1) Press & hold the Lock Button & pinch the two Spring Tabs together simultaneously (Fig C). Fold the Steering Bar down (Fig D) and slide the Frame Bracket towards the seat (Fig E).
- 2) Ensure the Frame Lock securely locks the vehicle in the folded position.



**Note: Only adults should fold and unfold the vehicle to avoid potential injury.**

## Important Battery and Charger Information

- Only an adult who has read and understands the safety warnings may handle and operate the battery and battery charger. Keep away from children.
- Charge the battery for 24 hours before using the vehicle for the first time.
- Charge the battery immediately after each use. Charge for at least 8-12 hours, but no more than 20 hours.
- Charge the battery at least once a month, even if the vehicle is not used or stored.
- Never leave the battery in a discharged condition.
- Connect the terminal of the battery and charger, then plug the charger into a 240V AC outlet.
- It is normal for the charger to heat slightly. If the charger temperature rises above 71°C / 160°F, disconnect the charger and call Customer Service for assistance.
- Keep the charger away from water or excessive moisture to prevent short-circuiting.
- Only use the charger specified with the original item. **Do not charge the battery with any other charger.**
- Do not attempt to recharge non-rechargeable batteries with the original charger.
- **Do not replace the battery with any other battery, otherwise the warranty will be voided.** If you need a replacement battery, see Page 20 for replacement information.
- Remove damaged batteries from the vehicle immediately. Recycle or dispose of the used batteries responsibly.
- Do not short circuit the supply terminals.
- Do not leave the battery connected in the vehicle for extended periods of time when the vehicle is not in use. Disconnect the battery connector from the engine connector before storing.
- The vehicle is equipped with a thermal fuse to protect the electric circuit. If the vehicle stops unexpectedly, turn the vehicle off and on to reset.

## 16 General Care

- Regularly inspect all vehicle parts to ensure they are in good working condition.
- Regularly inspect the charger, cord, plug, and other related parts for damage.
- Remove any damaged parts and immediately contact Customer Service for replacement parts. See Service and Repairs on Page 20 for more information.
- DO NOT operate the vehicle if there are any damaged parts.
- Carefully clean the vehicle with a damp cloth and mild soap. Do not get water in or near any electrical parts. Do not wash the vehicle with a hose.
- Store the vehicle indoors or use a tarp to cover it. Keep away from stoves, heaters, or other sources of heat.



# Troubleshooting Guide 17

Completely read through the manual and troubleshooting guide before contacting Customer Service.

Problem	Potential Cause	Solution
Vehicle does not run	Battery is low	Recharge the battery
	Thermal fuse tripped	Reset fuse
	Loose wires or loose connectors	Ensure the battery connectors are securely attached. If wires are loose, contact Customer Service.
	Battery is dead	Contact Customer Service for replacement battery
	Electrical system is damaged	Contact Customer Service
	Motor is damaged	Contact Customer Service
Vehicle only runs for a short time	Undercharged battery	Make sure there is a secure connection when the battery is recharging. Recharge for at least 8-12 hours
	Overcharged battery	Never charge the battery for more than 30 hours
	Battery is old	Replace battery
Vehicle runs slowly	Battery is not fully charged	Ensure a secure connection when the battery is recharging.
	Battery is old	Contact Customer Service to order a replacement battery.
	Too much weight on vehicle	Reduce weight on vehicle 25kg (55 lb)
	Harsh conditions	Operate the vehicle on level ground and safe surfaces

Problem	Potential Cause	Solution
Vehicle needs a push to start	Loose wires or loose connectors	Ensure the battery connectors are securely attached. If wires are loose, contact Customer Service.
	“Dead spot” on motor	A “dead spot” means electricity is not being delivered to the terminal. Contact Customer Service.
Cannot stop the vehicle	Electronic component is damaged	Contact Customer Service
Motor or gear box make grinding noises	Motor or gear damage	Contact Customer Service
Battery will not recharge	Charger is not plugged in	Plug the charger into a functioning wall outlet.
	Charger is not working	Call Customer Service for a replacement.
	Loose connector or loose adapter	Check that the connectors are securely plugged into each other.
Battery makes bubbling noise while recharging	This is normal	No action required
Battery makes noises and heats up when charging	This is normal	No action required

This device complies with part 15 of the FCC Rules. Operation is subject to the following two conditions: (1) this device may not cause harmful interference, and (2) this device must accept any interference received, including interference that may cause undesired operation.

This equipment has been tested and found to comply with the limits for a Class B digital device, pursuant to Part 15 of the FCC Rules. These limits are designed to provide reasonable protection against harmful interference in a residential installation.

This equipment generates, uses and can radiate radio frequency energy and, if not installed and used in accordance with the instructions, may cause harmful interference to radio communications. However, there is no guarantee that interference will not occur in a particular installation. If this equipment does cause harmful interference to radio or television reception, which can be determined by turning the equipment off and on, the user is encouraged to try to correct the interference by one or more of the following measures:

- Reorient or relocate the receiving antenna.
- Increase the distance between the equipment and the receiver.
- Consult dealer or an experienced radio/TV technician for help.
- Connect the equipment into an outlet on a circuit different from that to which the receiver is connected.
- Check the state or local requirements for the product before using the product.

**Caution:** Changes or modifications not expressly approved by the party responsible for compliance could void the user's authority to operate the equipment.

## 20 **Service and Repairs**

If your product requires service, repairs or replacement parts, please visit us online at [www.electricrideon.com.au](http://www.electricrideon.com.au)

Or contact us at:

Toll Free Service Phone: 1800 224 094

email: [www.enquiries@hunterproducts.com.au](mailto:www.enquiries@hunterproducts.com.au)

Hours: 9.00 AM - 5.00 PM (AEST), Monday - Friday

[www.electricrideon.com.au](http://www.electricrideon.com.au)

## One-Year Limited Warranty

Hunter Products warrants that your 6v vehicle will be free from defects in materials and workmanship for the vehicle (except for the 6-volt battery) for a period of 12 months, from the date of purchase. This warranty only applies where the product is completely and correctly assembled and used in accordance with all accompanying recommendations and users instructions. This warranty is in addition to your rights under the Australia Consumer Law.

Hunter Products, at its option will provide you with a refund or replacement parts for this product if the 6v vehicle becomes defective within the warranty period.

Hunter Products will bear the reasonable expense of claiming the warranty. This warranty will no longer apply where the defect is a result of an accident, misuse, abuse, neglect or other causes not arising out of defects in materials or workmanship, nor does it cover damages arising out of damages arising out of service by other than an authorised service person.

Our goods come with guarantees that cannot be excluded under the Australian Consumer Law. You are entitled to a replacement or refund for a major failure and compensation for any other reasonably foreseeable loss or damage. You are also entitled to have the goods repaired or replaced if the goods fail to be of acceptable quality and the failure does not amount to a major failure.

Please retain your receipt as proof of purchase and contact Hunter Products for further assistance on how to process any warranty claims.

**Business name:** Hunter Products Pty Ltd  
**Business address:** 233 Bay Street, Brighton, VIC 3186, Australia  
**Toll Free Phone:** 1800 224 094 (Monday to Friday 9.00 to 5.00pm AEST)  
**Email address:** enquiries@hunterproducts.com.au





