

Disney · PIXAR
LIGHTNING

**BLUETOOTH WIRELESS
STEREO HEADPHONES**



INSTRUCTION MANUAL

Please read these instructions carefully and retain for future reference.



DY-2004-LY

HIGHLIGHTS

- Bluetooth
- Built-in Microphone
- Aux Input
- SD Card Input
- Foldable
- Up to 13 Hours Playtime

PACKAGE CONTENTS

- Disney Lightyear Bluetooth Headphones
- Micro USB Charging Cable
- Aux Cable
- Instruction Manual

SPECIFICATIONS

- Bluetooth
 - Version: V 5.0
 - Chipset: AB5325B
 - Profiles: A2DP / AVRCP / HSP / HSF
 - Range: 10 m / 33 ft
- Battery: 400 mAh
- Charging Time: 2 Hours
- Charge Input: DC, 5 V, 0.1 A
- Play Time: 8 – 13 Hours
- Sensitivity: 85 dB
- Driver Size: 40 mm
- Impedance: 32 Ω
- Frequency Response: 50 Hz — 20 kHz

IDENTIFYING PARTS

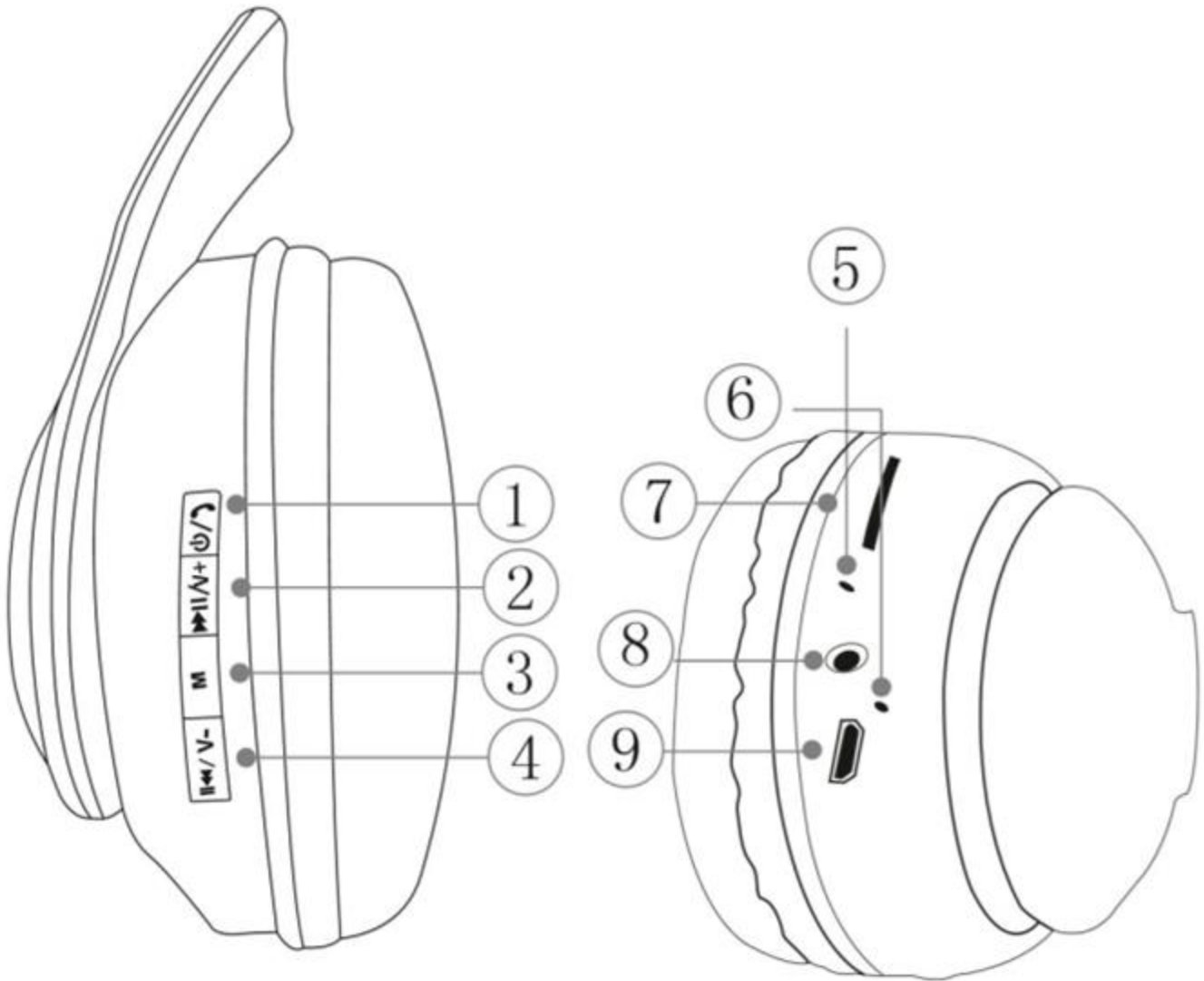

1. Power / Call / Play / Pause Button
2. Next Track / Volume Up Button
3. **M** Mode Button
4. Previous Track / Volume Down
5. Microphone
6. LED Indicator
7. SD Card Input
8. Aux Input
9. Micro USB Charging Input



INSTRUCTIONS FOR USE:

CHARGING

Please ensure that the battery is fully charged before using the Disney Lightyear Bluetooth Headphones for the first time.

- Connect the provided USB charging cable to the Micro USB Charging Input on the headphones.
- Connect the other end of the USB charger to a 5 V USB wall charger or USB port on your computer or laptop.
- The LED Indicator glows red while charging and will switch off when fully charged.

POWER ON/OFF

- To Power On, press and hold the  Power / Call Button until the LED Indicator lights up and flashes blue and green.
- To Power Off, press and hold the  Power / Call Button until the LED Indicator switches off.

BLUETOOTH MODE

PAIRING WITH BLUETOOTH DEVICES

Your headphones must be paired to a Bluetooth device before it can be used in Bluetooth mode. It is only necessary to pair your headphones once with each device.

Switch your headphones on before attempting to pair it to the device. When switched on, the headphones will automatically enter Bluetooth Pairing Mode, when the LED Indicators flash blue and green your headphones are ready to pair.

1. Open the Bluetooth Menu on the device you wish to pair (see “Locating the Bluetooth Menu” for more details). Some devices require you to select “Search for Devices” or Add New Device” in order to create a Bluetooth pairing.
2. Wait till you see “2004” on your device screen.
3. Select “2004” on your device and follow any further prompts to pair. Once pairing is complete and a connection is established, the headphones will emit a voice prompt indicating that the headphones is successfully connected, and the LED Indicator will glow solid blue.

LOCATING THE BLUETOOTH MENU

iPhone, iPad, and iPod Touch

- a) On your device, go to Settings.
- b) Select Bluetooth. If Bluetooth is not on, turn it on.
- c) The iPhone / iPad / iPod will automatically search for new devices.

Android™ Phones and Tablets

- a) On your device, go to the Settings Menu.
- b) Select Bluetooth (on older Android devices Bluetooth is found in the Wireless & Networks Menu). If Bluetooth is not on, turn it on.
- c) Select “Search for Devices” if your phone or tablet does not automatically search for new devices.

CONNECTING WITH PAIRED DEVICES

Once the headphones are turned on, it will automatically connect with the last paired Bluetooth device that is on and within range. If the headphones do not connect automatically, open the Bluetooth Menu on your device and select “2004” from the Bluetooth device list.

CONTROLS

Short press the **M** Mode Button to navigate between Bluetooth and Aux Modes. The headphones will automatically enter TF / Micro SD Card Mode when a compatible TF / Micro SD Card is inserted into the SD Card Input.

1. Adjusting the Volume

FUNCTION	OPERATION
Increase Volume	Press and hold the ►► / v+ Volume Up / Next Track Button.
Decrease Volume	Press and hold the ◀◀ / v- Volume Down / Previous Track Button.

2. Navigation / Track Selection

FUNCTION	OPERATION
Navigate to Next Track	Short press the ▶▶ / v+ Volume Up / Next Track Button.
Navigate to Previous Track	Short press the ◀◀ / v- Volume Down / Previous Track Button.
Play or Pause Track	Short press the ⏮ / ⏭ Play / Pause / Call Button.

Note: These functions will not work in AUX Mode.

3. Hand-free Calling

FUNCTION	OPERATION
Incoming Call	Answer Call Short press the ⏮ / ⏭ Play / Pause / Call Button.
	Reject Call Press and hold the ⏮ / ⏭ Play / Pause / Call Button.
Call in Progress	End Call Short press the ⏮ / ⏭ Play / Pause / Call Button.
Call Last Dialed Number	Short press the ⏮ / ⏭ Play / Pause / Call Button.

Note: Only when your headphones are Bluetooth connected to your Smartphone will you be able to answer or reject calls via your headphones.

AUX MODE

To enter AUX Mode, plug an Aux Cable into the AUX Input on the headphones and the other end of the cable into the device that you wish to play audio from.

Note: In AUX Mode, only the volume controls will function. All other functions must be controlled from the connected device.

SAFETY PRECAUTIONS

- The product should only be used with the parts provided by the manufacturer.
- This product is intended for indoor use only.
- Never use your headphones near water or in areas where it can come into contact with water. Never handle the headphones if it has been dropped in water or any other liquid. If the product comes into contact with water while still plugged in, this is a safety hazard.

- Always make sure your hands are dry before touching the USB Cable or power connections.
- Do not operate the headphones with a damaged cable, after it malfunctions, has been dropped or damaged in any manner.
- The headphones are intended for personal use only. Commercial use invalidates the warranty and the supplier cannot be held responsible for injury or damage caused when using the device for any other purpose than that which it was intended for.
- The headphones are not intended for use by children, persons with reduced physical, sensory or mental capabilities, or lack of experience and knowledge, unless they have been given supervision instructions concerning use of the device by a person responsible for their safety. Extreme caution must be exercised.
- Children should be supervised to ensure that they do not play with the headphones. Packaging must never be left within reach of children since it is potentially dangerous.

CLEANING AND CARE INSTRUCTIONS

- **Before cleaning:** Ensure that your headphones are switched off and not charging before cleaning or maintaining it.
- **Cleaning:** Wipe down the surface of your headphones using a soft, slightly damp cloth.
- Do not use any harsh or abrasive cleaning chemicals or materials on your headphones as doing so may damage or scratch the surface finish.
- Do not expose your headphones to direct sunlight or high temperatures for extended periods of time.
- Do not store in temperatures over 140 °F (60 °C).

TROUBLESHOOTING

1. My mobile phone cannot find any new Bluetooth devices?

- a) Ensure the device has entered a Bluetooth pairing mode.
- b) Ensure the device is within an effective working range.

2. Bluetooth device cannot pair up.

Ensure your mobile phone allows new connections and has not reached the maximum number of allowed devices.

3. The device does not play music or answer calls when it is connected to a Bluetooth mobile phone.

- a) Ensure your mobile phone supports A2DP and HSF (Hands-Free) profiles.
- b) Ensure your mobile phone is within an effective working range.

4. When paired with my computer, Windows® asks for a new driver. Can you supply this?

We recommend you find compatible drivers for your computer online.

5. Why can I not remotely control the Pause / Play function when music is playing?

This feature needs the Bluetooth device paired with the headphones to support AVRCP (Audio/Video Remote Control Profile). Please ensure your device supports this.

ENVIRONMENTALLY FRIENDLY DISPOSAL



At the end of its working life, the product must not be disposed of as urban waste. It must be taken to a special local authority differentiated waste collection centre or to a dealer providing this service. Disposing of a household appliance separately avoids possible negative consequences for the environment and health

deriving from inappropriate disposal and enables the constituent materials to be recovered to obtain significant savings in energy and resources. As a reminder of the need to dispose of household appliances separately, the product is marked with a crossed-out wheeled dustbin.

- Never dispose of used electronics with ordinary solid waste, since they contain toxic substances.
- Always dispose of used electronics in accordance with the prevailing community regulations that apply to the disposal of electronics. If there are no regulations concerning electronics disposal, please dispose of the device in a waste bin for electronic devices.