

anko

ICED COFFEE MAKER

CM2101CE

USER MANUAL

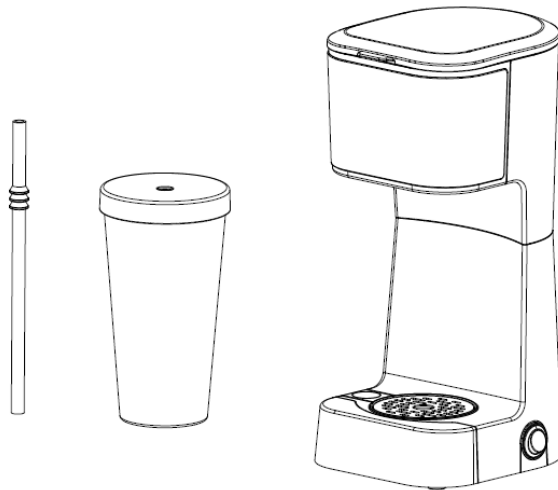

**PLEASE RETAIN THESE INSTRUCTIONS FOR
FUTURE REFERENCE.**

IMPORTANT INSTRUCTIONS

- This appliance is not intended for use by persons (including children) with reduced physical, sensory or mental capabilities, or lack of experience and knowledge, unless they have been given supervision or instruction concerning use of the appliance by a person responsible for their safety.
- Children should be supervised to ensure that they do not play with the appliance.
- Cleaning and user maintenance shall not be made by children without supervision.
- If the supply cord is damaged, it must be replaced by the manufacturer or its service agent or a similarly qualified person in order to avoid a hazard.
- This appliance is intended to be used in

-
- household and similar applications such as :
- staff kitchen areas in shops, offices and other working environments;
 - farm houses;
 - by clients in hotels, motels and other residential type environments;
 - bed and breakfast type environments.
- The appliance must not be immersed.
 - Do not place the appliance in a cabinet when in use.
 - Heating element surface is subject to residual heat after use.
 - Use the appliance according to this instruction, any misuse may cause electric shock or other hazards.
 - Regarding how to clean the surfaces in contact

food, please refer to section <Cleaning >.

- Before connecting the appliance, please check if the voltage indicated on the appliance corresponds with the main voltage in your home.
- Do not place the appliance on a hot surface.
- Do not use this appliance outdoors.
- Remove the main plug from the wall socket;
 - if problems occur during making coffee;
 - before cleaning the appliance.
- Do not allow the main cord to come into contact with hot surface.
- Use the appliance out of children reach. Prevent them from pulling the main cord.
- Do not pour any water before the appliance has been turned on.
- To fill the water tank, use fresh cold water only.

FEATURES OF COFFEE MAKER

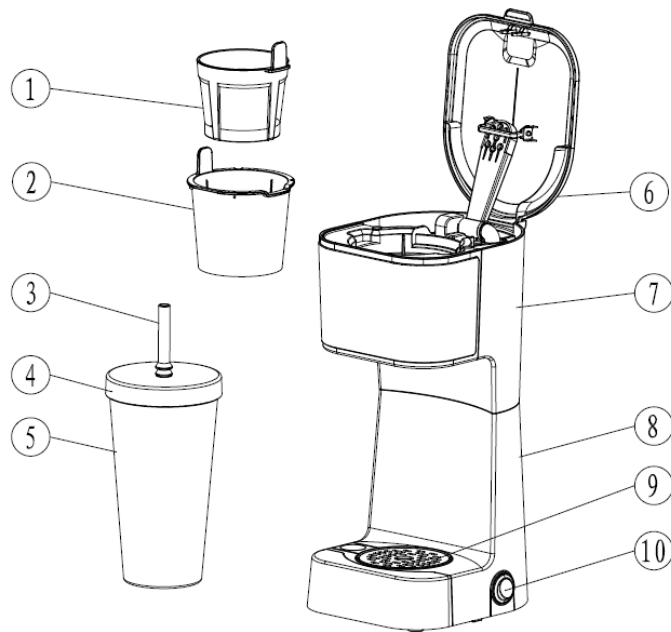

1. Filter
2. Funnel
3. Straw x2
4. Mug lid x2
5. Mug x2
6. Top cover
7. Water tank
8. Base
9. Collecting tray
10. Switch

Before first use

- Wash the coffee filter, funnel, straw and mug with mild detergent and water. Rinse each thoroughly.
- Fill in water tank to “MAX” level, replace the filter and funnel in position and put the mug under the drip spout.
- Switch on the unit and brewing will start.
- When brewing is complete, discard water from the mug. Rinse thoroughly with clean water.
- Repeat the full tank brewing for 2 to 3 times.
- Your Ice Coffee Maker is now ready for use.

Making ice coffee

- Fill mug to “Water” marking with clean, filtered water.
 - Pour the water into water tank.
 - Put in the filter and funnel, place desired quantity of ground coffee into the filter.
- Note:** if you want a bolder cup of coffee, you can use 2 scoops of ground coffee but not more than 20g. Once scoop is around 8-10g.
- Close the lid.
 - Fill the mug with ice until “Ice” marking and put it under drip spout.
 - Switch on the appliance and brewing will start now.
 - Wait for 1-2 minutes for brewing to complete. Once dripping slows and stops, switch OFF the unit.
 - Remove the mug, put on the lid and insert the straw. Your cold coffee is ready now.

Making more coffee straight away?

- If you have made one cup of coffee and wish to make some more straight away, please switch off the coffee maker between uses and allow at least 5 minutes for it to cool down. Then you can refill the water tank.

Cleaning

- Always remove the main plug from the wall socket before cleaning the appliance.
- Never immerse the appliance in water.
- You should clean it with a damp cloth.
- The mug and the filter and the funnel can be washed in hot soapy water.

Descaling

- Descale your coffee maker regularly.
- Operate the appliance as described. However, now use ordinary vinegar to fill the water tank and do not fill the funnel with ground coffee.
 - After descaling let the appliance work twice more with only water to rinse away the vinegar and scale remainders.

TECHNICAL DATA

Voltage: 220-240V~ 50-60Hz

Power: 600-700W

12 MONTH WARRANTY

Thank you for your purchase from Kmart.

Kmart Australia Ltd warrants your new product to be free from defects in materials and workmanship for the period stated above, from the date of purchase, provided that the product is used in accordance with accompanying recommendations or instructions where provided. This warranty is in addition to your rights under the Australian Consumer Law.

Kmart will provide you with your choice of a refund, repair or exchange (where possible) for this product if it becomes defective within the warranty period. Kmart will bear the reasonable expense of claiming the warranty. This warranty will no longer apply where the defect is a result of alteration, accident, misuse, abuse or neglect.

Please retain your receipt as proof of purchase and contact our Customer Service Centre on 1800 124 125 (Australia) or 0800 945 995 (New Zealand) or alternatively, via Customer Help at Kmart.com.au for any difficulties with your product. Warranty claims and claims for expense

incurred in returning this product can be addressed to our Customer Service Centre at 690 Springvale Rd, Mulgrave Vic 3170.

Our goods come with guarantees that cannot be excluded under the Australian Consumer Law. You are entitled to a replacement or refund for a major failure and compensation for any other reasonably foreseeable loss or damage. You are also entitled to have the goods repaired or replaced if the goods fail to be of acceptable quality and the failure does not amount to a major failure.

For New Zealand customers, this warranty is in addition to statutory rights observed under New Zealand legislation.