

Assembly Instruction

43267194 CHUNKY RIBBED SIDE TABLE

CARE INSTRUCTIONS:





WIPE CLEAN WITH A SOFT DAMP CLOTH. DO NOT USE ABRASIVE MATERIALS AND SOLVENTS. CHECK AND TIGHTEN ALL PARTS REGULARLY. DO NOT PLACE HOT ITEMS SUCH AS COFFEE CUPS DIRECTLY ON THE SURFACE. KEEP AWAY FROM WATER AND DIRECT SUNLIGHT. STORE IN A DRY PLACE. FOR DOMESTIC USE ONLY. FOR INDOOR USE ONLY. A MILD ODOUR MAY BE PRESENT WHEN FIRST OPENING THIS CARTON. SIMPLY ALLOW TO AIR OUTSIDE AND THIS WILL FADE.

WARNING:

DO NOT STAND OR SIT ON THIS UNIT. DO NOT USE THIS UNIT UNLESS ALL BOLTS AND SCREWS ARE FIRMLY SECURED. DO NOT KNOCK OR DRAG THIS UNIT. USE ONLY ON A FLAT SURFACE. THIS PACKAGE CONTAINS SMALL PARTS AND SHARP POINTS. KEEP AWAY FROM CHILDREN AND BABIES. ADULT ASSEMBLY REQUIRED. FAILURE TO FOLLOW THESE WARNINGS COULD RESULT IN SERIOUS INJURY.

MAXIMUM SAFE LOAD: 10KG FOR TABLE TOP.

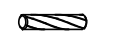
Hardware List

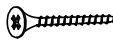
	A	4x25mm	8pcs		D		12pcs
	B	6x30mm	2pcs		E	6x20mm	2pcs
	C	4x35mm	20pcs				

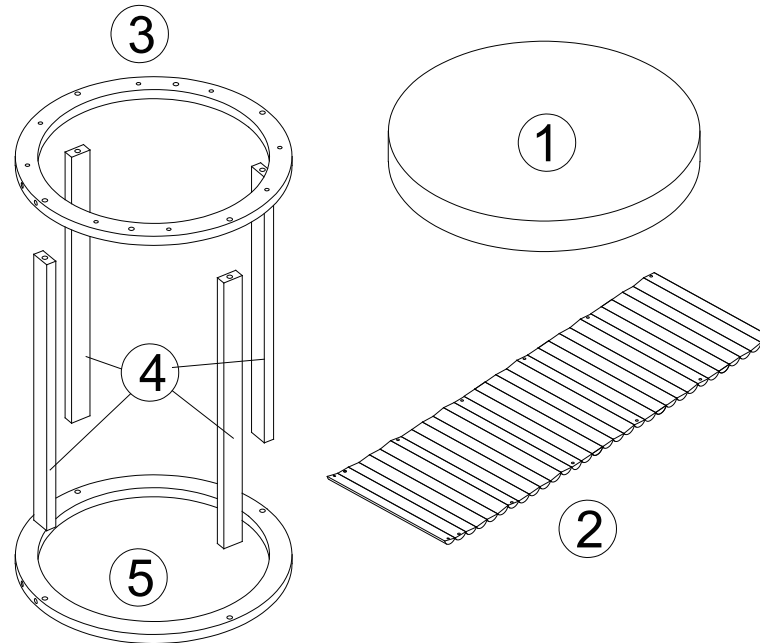

Do not tighten the screws fully during assembly.
Fully tighten screws after the final assembly steps.

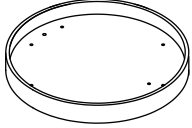
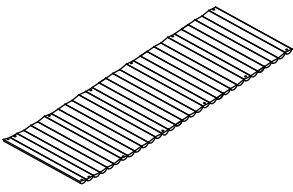
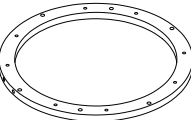
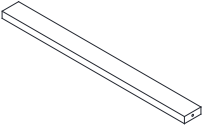
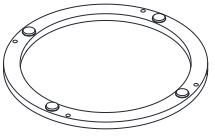
									
①	1 PC	②	1 PC	③	1 PC	④	4 PCS	⑤	1 PC

Step 1:

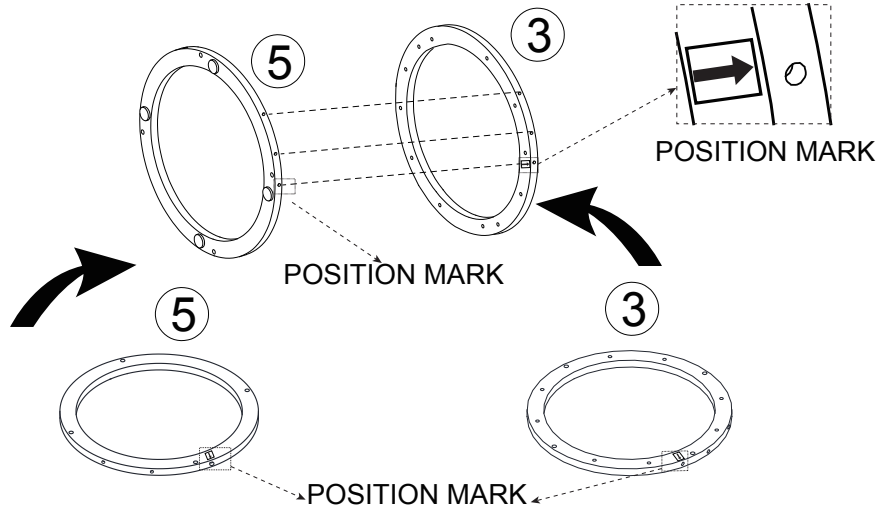

ATTENTION: CHECK THE POSITION MARK ON THE BOARD.
THEN ALIGN MARK AND ALL SCREW HOLES ON 3&5.

Step 3:

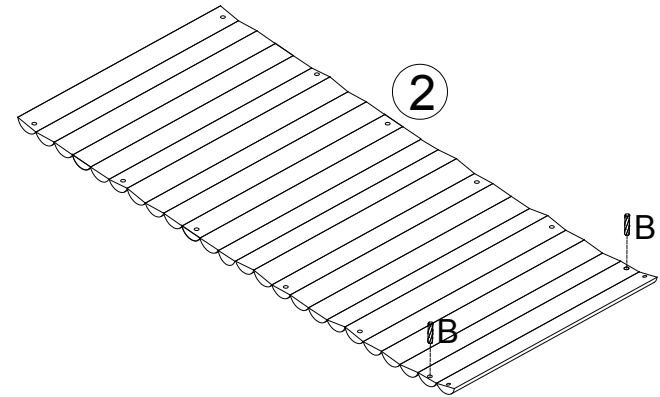
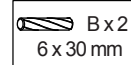

Step 2:

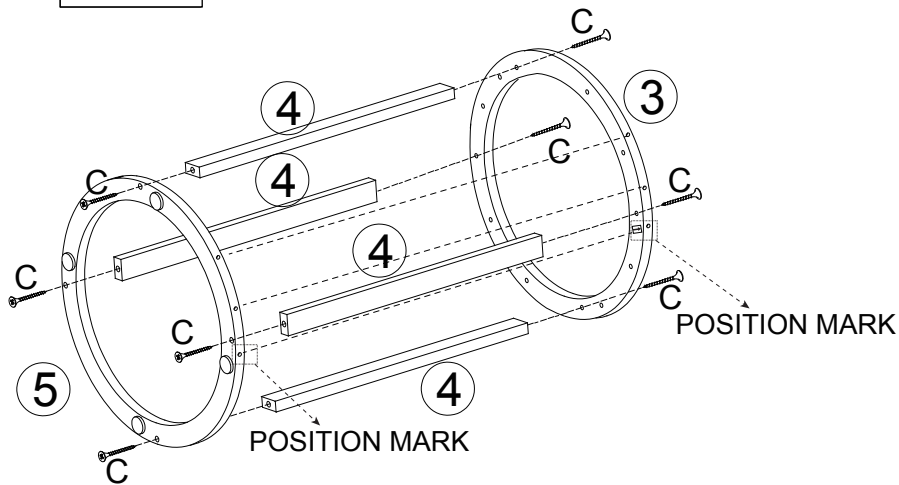
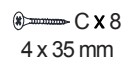

ATTENTION: LOCK PART 4 WITH C SCREW AND KEEP ALL SIDE
SCREW HOLES. POSITION MARK ARE ALIGNED.

Step 4:

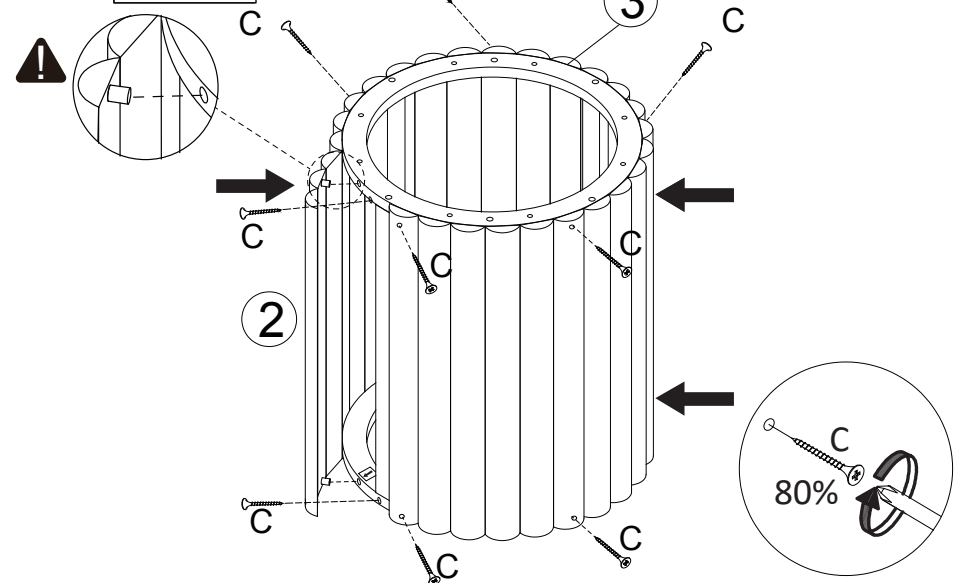
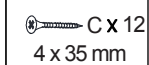

ATTENTION: PLEASE LOCK C SCREW AT 80% AND DO NOT FULLY TIGHTEN.

Step 5:

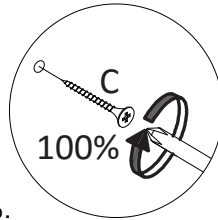
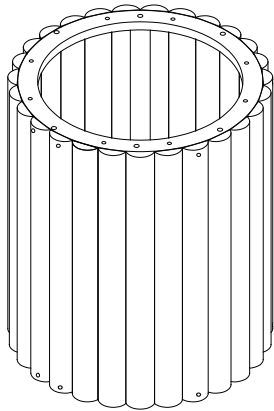

ATTENTION: PLEASE TIGHTEN ALL SCREWS AT 100%.

Step 7:

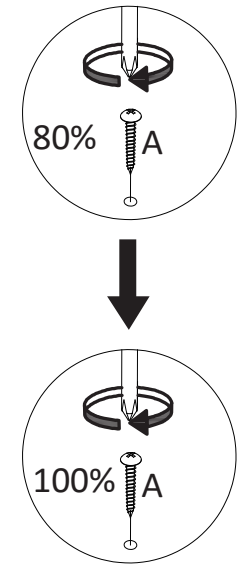
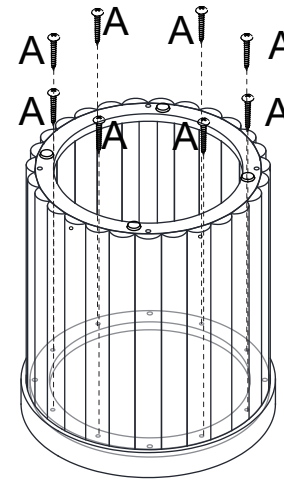
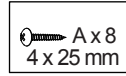

ATTENTION: PLEASE LOCK A SCREW AT 80% BEFORE ALL THE HOLES ALIGNED, THEN TIGHTEN ALL SCREWS AT 100%.

Step 6:

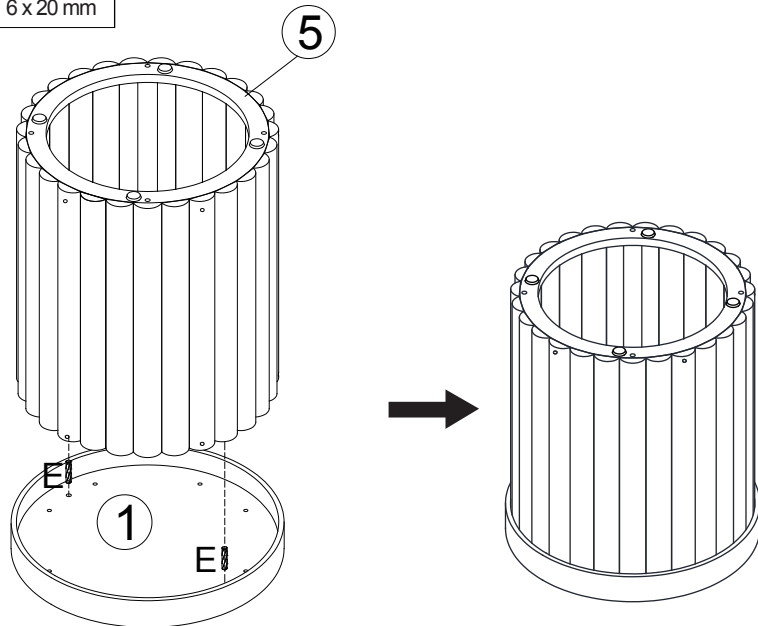
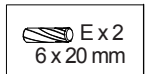

Step 8:

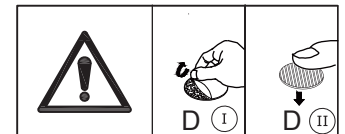
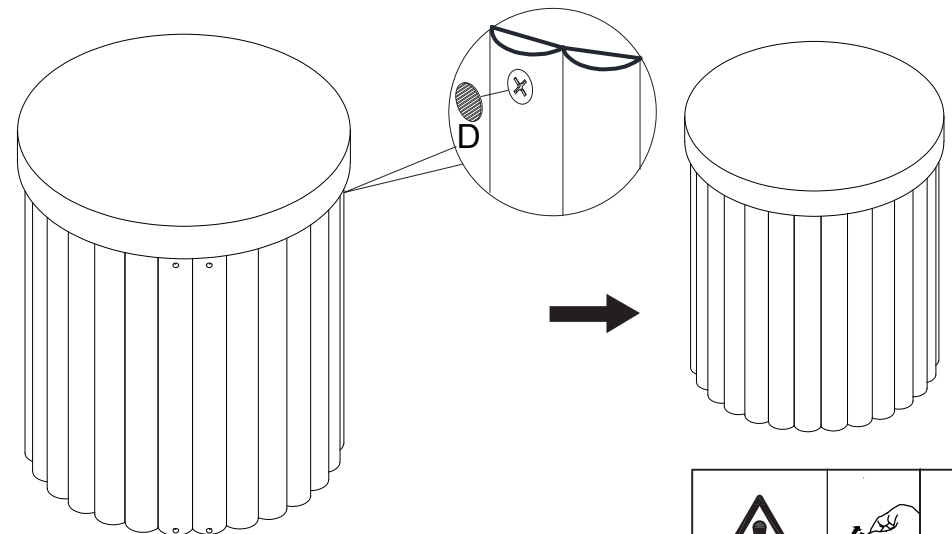

D (I)

D (II)