

# Cars 2 in 1 Balance Bike Instruction Manual

Keycode: 43313112

Congratulations in purchasing Cars 2 in 1 balance bike. The aim of the balance bike is to assist in the development of your child's balance, coordination and steering, as well as to build strength and motor skills. Your child will be able to learn how to ride with ease. Please pay attention to the following safety guidelines.

## Important Safety information:

1. Recommended for children under 3 years.
2. Check all parts are in good condition and that screws and tyres are tightened correctly.
3. Protective gear should always be worn when riding any bike (helmet, protectors for knees, elbows and wrists).
4. Always ensure that appropriate footwear is worn whilst riding this bike.
5. Maximum weight is 20kg.
6. Only ONE person to ride this bike at any given time.
7. This bike is not intended for stunting or tricks.
8. Do not use on roadways. Always ride in a safe environment such as a park or private property.
9. This balance bike is not constructed for uneven paths, stairs, steep hills, or other rocky surfaces. Damage may be done to the bike and to the rider. Only use on flat surfaces.
10. Adult supervision is required at all times.
11. Check the child's feet can rest on the ground whilst astride the balance bike by adjusting the seat height before allowing child to ride this bike.

## Contents of the package

**Note!** Certain bike parts, like the frame, saddle and two screws with nuts were pre-assembled in factory. Check if the package is complete and does not show any traces of damage. Should you find some parts missing or damaged, do not use the bike but contact the Kmart Customer Service Team.

Keep the packaging or utilize it as required by the local regulations.

**Caution!** For the safety of kids do not leave parts of the packaging (plastic bags, blisters, boxes, styrofoam etc.) freely available. Risk of suffocation!

## Cleaning and maintenance

- Clean the bike with a damp cloth or sponge.
- Protect the run bike from dust, humidity, water, extremely high and low temperatures, damage etc.

**WARNING:** Item to be assembled by adult only. Choking hazard, contains small assembly components with functional sharp points and edges.

## PARTS AND HARDWARE LIST

A. FRAME X 1PC

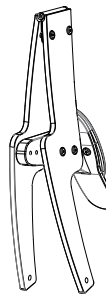

B. FRONT FORK X 1PC



C. EVA WHEELS X 3PCS

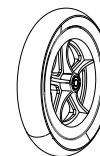

D. WOODEN SPACERS X 3 PCS



E. HANDLEBAR X 1PC

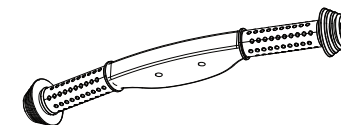

F. STEERING ROD X 1PC



G. SCREW X 2 PCS



H. NUT X 1PC



I. LONG BOLT X 1PC



J. SPACER NUT X 2 PCS



K. HARDWARE SET FOR BALANCE BIKE



L. HARDWARE SET FOR TRIKE

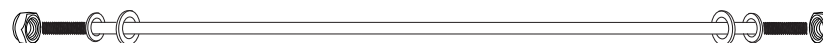

## STEP OF ASSEMBLY

1. Pull out the pre-inserted steering rod (part F) in the front fork.

To avoid losing hardware, the steering rod is pre-inserted in assembling position.

Attention: Do not adjust the holding bolt in the middle of the front fork.

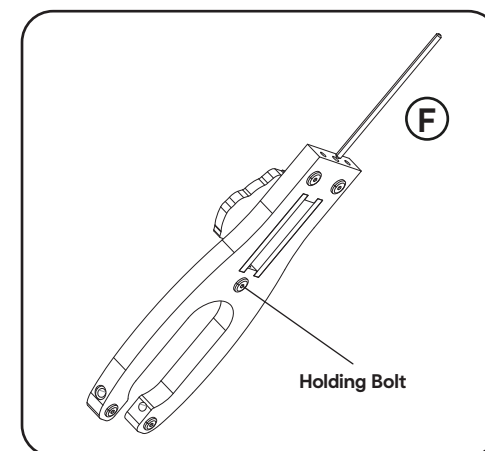

2. Attach the frame to the front fork by Inserting the Frame into the front fork.  
Insert the steering rod (part F) into the hole until the steering rod is completely inserted.

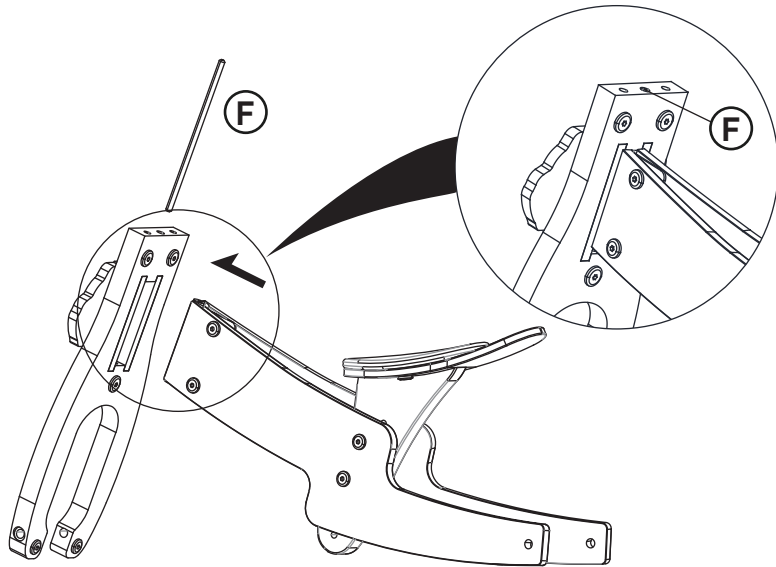

3. Place the handlebar onto the front fork and attach them with 2 pcs of screws (part G).

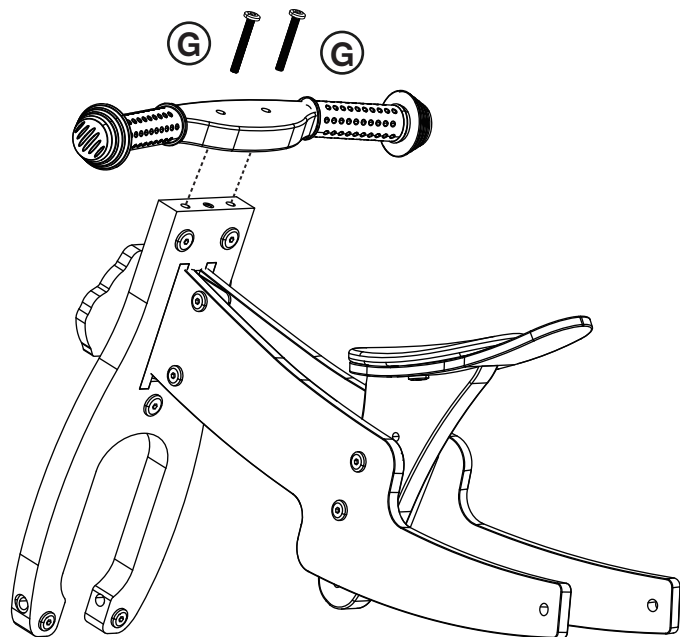

4. Attach the front wheel to the front fork with Long bolt (part I ) and Nut (part H) as well as 2 pcs of spacer nuts (part J ) provided.

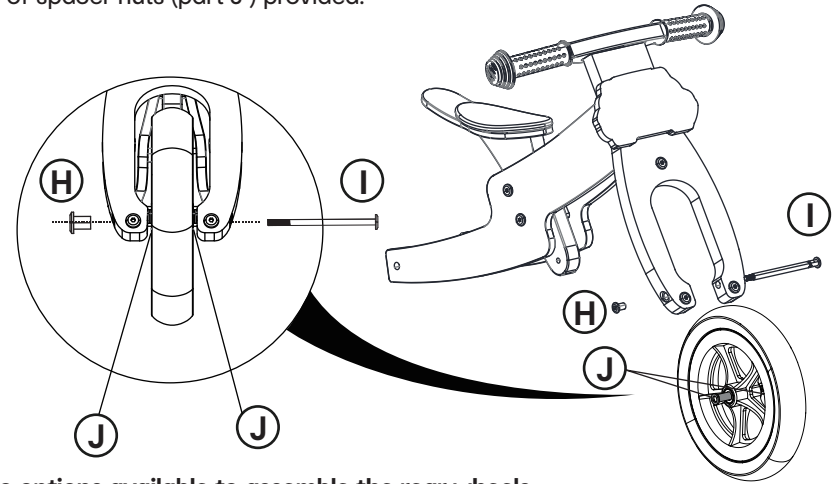

5. Two options available to assemble the rear wheels.

1. Assemble only one rear wheel to a balance bike with hardware set (part K) as below.
2. Assemble two rear wheels to a trike with hardware set (part L) and wooden spacers (part D).

NOTE:

1. PAY SPECIAL ATTENTION TO THE POSITION OF WOODEN SPACERS AS BELOW.
2. USE THE ALLEN KEYS / WRENCHES TO TIGHTEN THE NUTS AT TWO SIDES SIMULTANEOUSLY.

