

Please read the manual before using the product. The manual and carton contain important information, please keep them for future reference. Failure to follow the instructions in the manual might be dangerous for your child.

In order to improve the product and quality, we may change the parts of structure, appearance, packing method, assembly method and function of the product without any notice. When there is any difference between the manual and the product, please refer to the actual product. We are sorry for any inconvenience.

The assembly manual of  
battery operated car











**Model: SX2018**

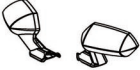

**⚠ WARNING:**

Products should be assembled by an adult. Protective equipment should be worn. Not to be used in traffic. Not suitable for children under 3 years. Choking hazard- small parts. In unassembled state, contains potentially hazardous small parts. Please keep out of the reach of small children. Pay attention to the potential hazards of using the toy in areas other than private grounds.

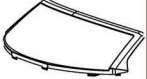
## PARTS LIST

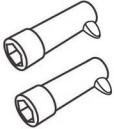
PARTS NAME	PICTURE	QTY	PARTS NAME	PICTURE	QTY
Car body		1PC	Steering wheel		1PC
Seat		1PC	Spoiler		1PC
Mirror		2PCS	Front wheel		2PCS
Charger		1PC	Rear wheel		2PCS
Wheel cover		4PCS	Windshield		1PC
Manual		1PC	Socket wrench		2PCS

### Disclaimer:

The pictures in this instruction manual are for assembly reference only. Please refer to the actual product.

### WARNING:

This product is not a vehicle for transportation, it should be used under adult guidance. Parents should ensure that children have taken note of the safety measures before use.

The toy should be used with caution since skill is required to avoid falls or collisions causing injury to the user or third parties.

“This toy contains batteries that are non-replaceable”.

## PRODUCT SPECIFICATIONS

Battery	12V7AH
Main material	PP
Suitable age	3-8 years
Weight limit	30kg
Product size	1.075x0.65x0.43m
Speed	3-5KM/H
Runtime	1-2 hours after charging 8-12 hours, based on ride on conditions
Charger	Input AC 220-240V Output DC 15V0.8A
Fuse	Auto-reset fuse

## Assembly instructions

Car assembly should be actioned by adults.

Take care of small parts. To avoid choking hazard, keep children away while assembling. Children under 3 years are prohibited to use product.

Please count all the parts carefully before assembling and dispose the plastic bag properly. To avoid choking hazard, children are not allowed to play with the bag.

### 1.Front wheel assembly

Remove the washers and nuts on each side of front axle. Insert the 10mm inner diameter washers into the front axle, install the wheels and 8mm inner diameter washers, fix the nuts on both sides with the socket wrenches at the same time. While applying pressure lock wheel covers into grooves on the wheels.

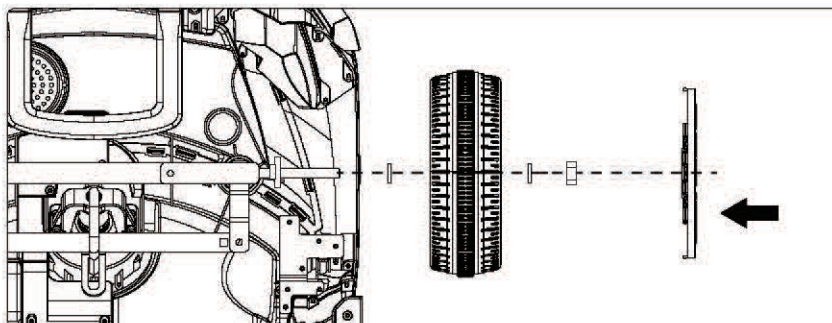

## 2.Rear wheels assembly

First, check whether the rear axle is in the middle of the car, make sure the axle length that extends out on both sides are the same.

Remove the washers and nuts on each side of the rear axle. Install the wheels and 8mm inner diameter washers, fix the nuts on both sides with the socket wrenches at the same time. While applying pressure lock the wheel covers into grooves on the wheels.

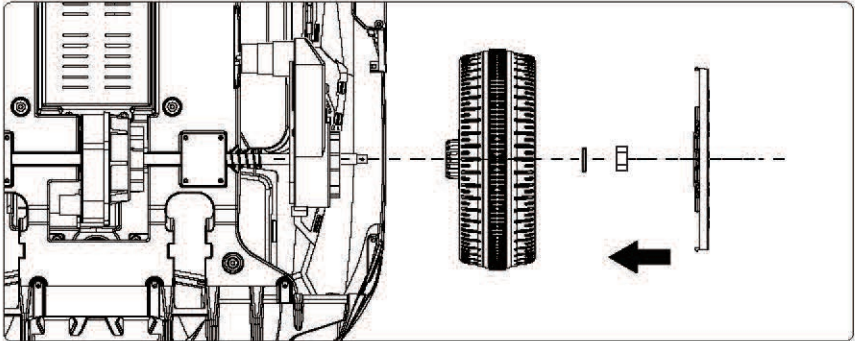

### Attention:

After completing one side of the wheel installation, turn over the car body, make sure that the assembled wheel is in contact with the ground, pull out the rear axle until it can't move, then assemble the other wheel.

## 3.Windshield assembly

Align the windshield with the corresponding openings on the car body, insert and push it into place.

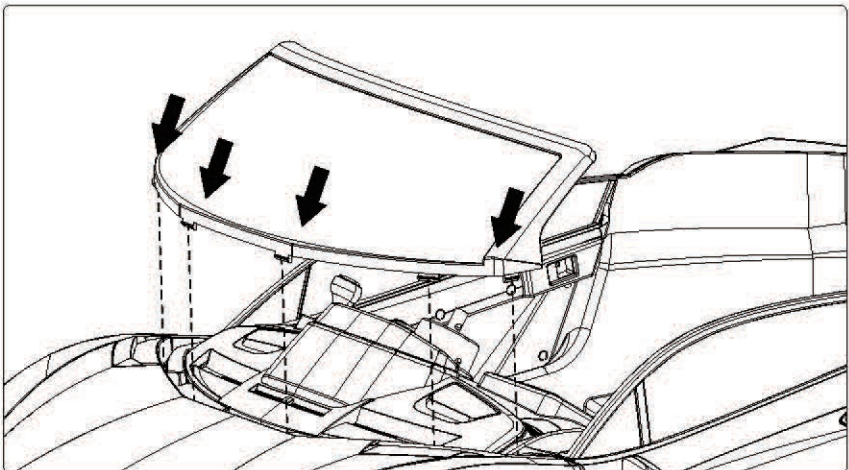

#### 4. Steering wheel assembly

Match the two connectors of the wires from the steering wheel and steering column, align the steering wheel with steering column, press the two pins on the steering wheel and insert them into the holes on the steering column.

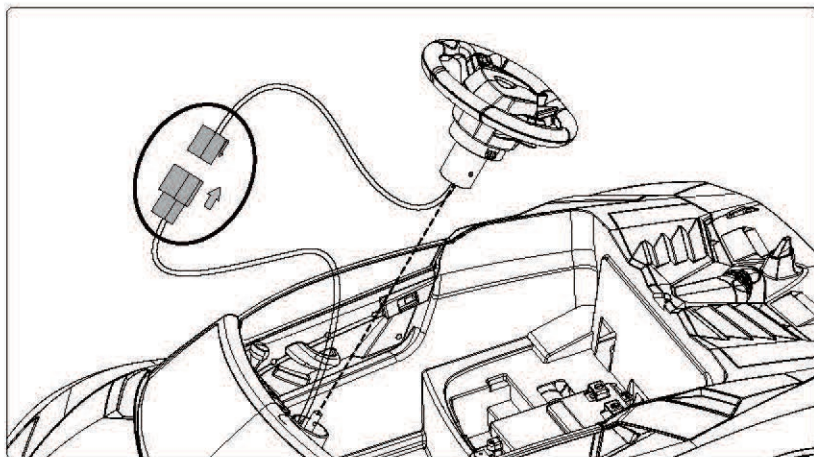

#### 5. Battery connection

Before assembling the seat, please connect the two red clip locks of the two wires.

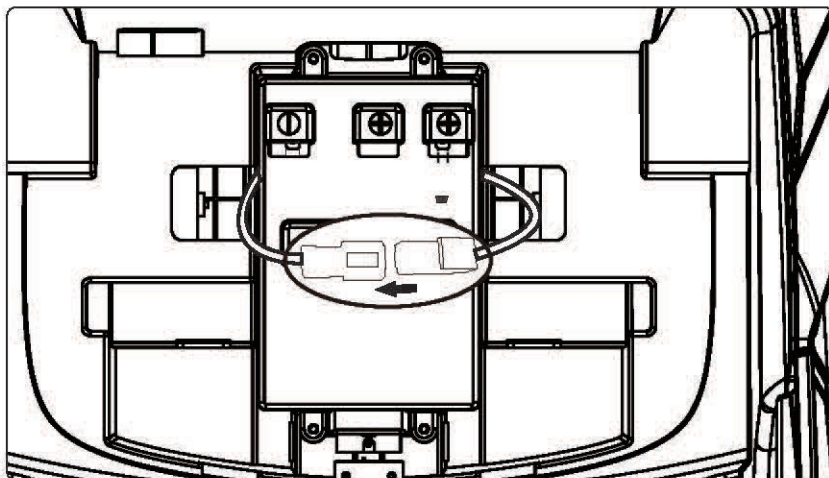

## 6.Seat assembly

Remove the seat screw from the car body. Align the seat diagonally with the corresponding position on the car body, and insert the hooks. Fix into place with the self tapping screws at the back of the seat.

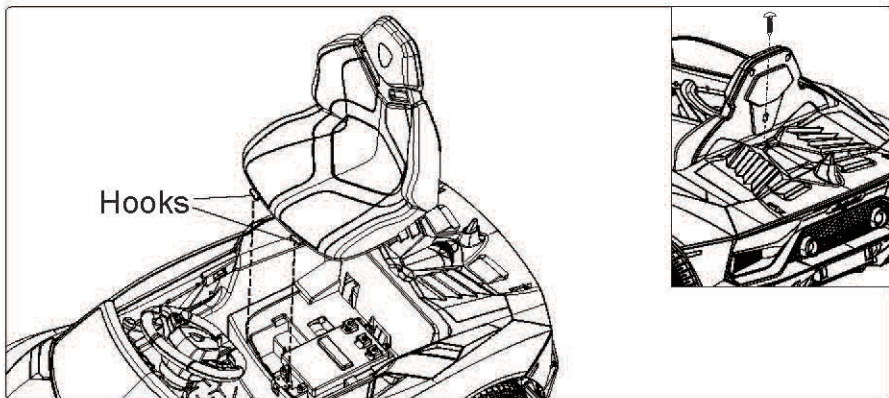

## 7.Spoiler assembly

Insert the spoiler into the corresponding position at the rear of the car and push it into place.

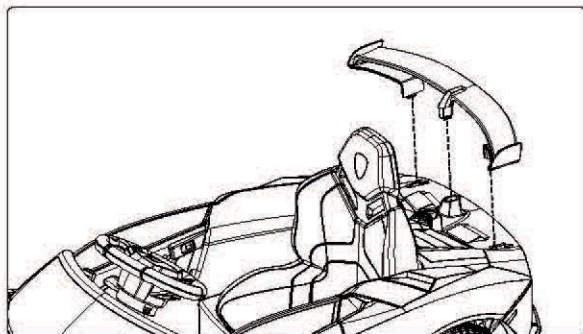

## 8.Mirror assembly

Align the mirror with the corresponding opening on the car body, insert and push it into place.

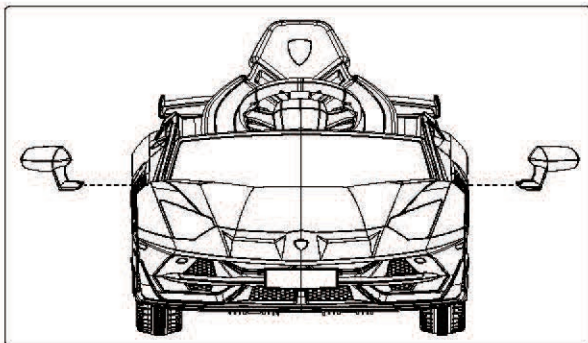

## FUSE

This car has an auto-reset fuse, if the car stops suddenly whilst driving, it is likely due to exceeding the currents which have caused the fuse to trip. To reset the fuse, stop operating the vehicle and turn it off for around 8 seconds, then turn on the power switch again. In order to avoid the fuse tripping and cutting off power supply, please pay attention to the following:

- ①. This product can't be overloaded, the maximum load is 30kgs.
- ②. Don't drag anything behind the product.
- ③. Don't let water or other liquid into the batteries and other electrical components.
- ④. Don't change the circuit system and structure of the product.

## SECURITY WARNING

1. The installation and charging of the vehicle should only be completed and actioned by adults.
2. This product is limited to children aged between 3-8 years, 30 kg weight limit. Please do not overload. Only one rider at a time.
3. This product is ideal for driving on a hard flat surface.
4. It is strictly prohibited in the streets or the road, pot holes, and slopes.
5. Avoid driving in the sand, grass or uneven ground.
6. Children should be given full instructions on operation of the car. Improper operation can cause damage or accidents.
7. While children are driving, it is the supervising adults duty to supervise at all time to avoid accidents.
8. Avoid driving in rain or flooded pathways. By doing so it can damage the motor, circuit and other electrical equipment.
9. Battery charger should be regularly inspected by supervising adults to ensure that the wires, plugs, crusts and other components are not damaged. Please stop using if any damage is found, until it is completely restored.
10. In order to ensure product life and safety, avoid damage to the charger, battery or electric circuit, the car must use the default configuration of a dedicated charger and power supply.
11. Rechargeable batteries should be removed before charging.
12. When the vehicle is not in use, please ensure that the switch is set to "stop or "off".
13. The charger provided is not a toy. It is to be kept away from children.
14. It is prohibited to use parts that are not provided by the manufacturer.

## USAGE DIRECTION

1. Before use, make sure that all the following are done.

- Ensure all steps as per the instructions are followed and completed for proper installation. Ensure the battery has been connected and all screws are fixed tightly. Ensure the power supply is switched to 'ON' before use.
- Supervising adults need to have read and understood all safety measures stated and ensure child is well prepared and aware of the safety measures before allowing child to use the car.

To reduce the risk of injury, please ensure the following measures are taken into account:

- Supervising adults are to supervise the child at all times when using the car.
- Be aware of the driving and weather conditions to ensure and maintain a safe environment at all times. The car should only be used on hard, flat, dry surfaces.

Examples to be aware of:

- \* Slopes, trenches, riverside, uneven ground
- \* Roads, pathways and other places for driving and walking.
- \* Obstructions that may cause injury To avoid any accidents, please only use during the daytime; avoid using at night or where there is low visibility to the user and supervisor.

### WARNING:

When changing gears, the accelerator should be released, and the car should come to a complete stop. Do not change the gears while the car is still moving as this can damage the wires and other transmission parts.

### 2. Operating(function reference diagram)

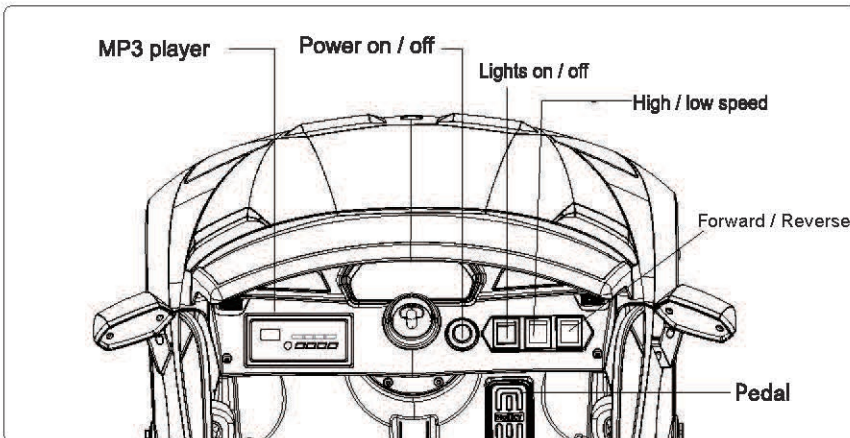



## MP3(Optional)

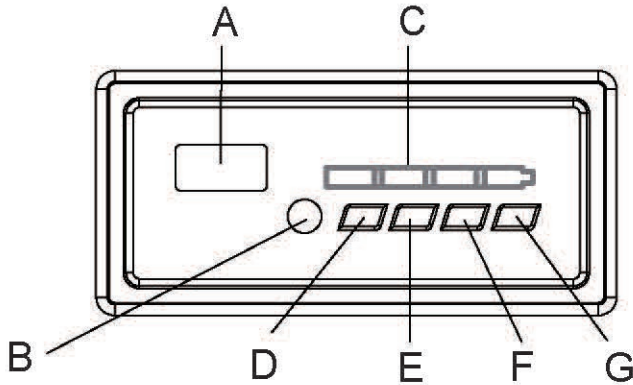

A:USB socket

B:AUX socket

C:Battery metre

D:Press for music/Hold down to reduce the volume.

E:Press for music/Hold down to pause

F:Press for music/Hold down to increase the volume

G:AUX/USB mode switch

## How to Charge

- For Safety purposes ,the charging must be done by adults.
  - The first time you use it, please remove the seat and connect the two clip locks of red wires.Use it only after charging 8-12 hours.
  - Charging socket is located on the dashboard, please follow the instructions to charge the battery.
  - If the car has slowed down, it needs to be charged 8-12 hours, maximum 20 hours.
- 1.First insert the plug of the charger into the charging port. (Turn off the car before charging.)
  - 2.Then insert the charger to the power socket.

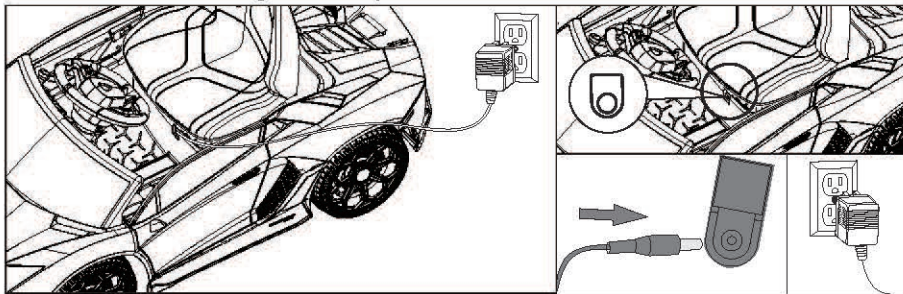

### **WARNING:**

- 1 The toy is to be assembled by an adult. In unassembled state, it contains potentially hazardous sharp points & small parts, so please keep out of the reach of children under the age of 3.
- 2 CHOKING HAZARD – Small parts.
- 3 Not for children under 3 years.
- 4 Always wear shoes.
- 5 RISK OF FIRE. Do not bypass. Replace only with circuit protection device.
- 6 Protective equipment should be worn. Not to be used in traffic.

### **Attention:**

- Only use the charger and battery according to the manufacturers regulations.
- Do not mix old and new or different types of batteries.
- The battery terminal should not be short circuited.
- Do not open the battery or charger.
- Do not reverse the battery.
- Before charging, please check whether the charger, battery and plug are ok, if you find any broken parts, you must stop using it immediately. And do not use it until it is fully repaired.
- The battery will be little warm when being charged, it is normal. If not, it may be caused from the short circuit of the charger or circuit board.
- Ensure use of the pressing plate to fix the battery.
- An exhausted battery must be handled by adults, remove the battery and recycle properly. This should not be arbitrarily discarded.
- If the product is going to be stored or unused for a long time, ensure that it is fully charged. Charge the battery monthly to ensure and maintain battery life.
- Charger and Battery are not toys. Keep them away from children.

## MAINTENANCE AND SERVICE

- 1, Before use, supervising adults should check whether all parts like batteries, charger, wires, plug, outer body and other parts are in good condition, check whether the screws are loose and whether there are potential safety hazards. Any damaged parts should be repaired before using.
- 2, After using the product for a period of time, use a small amount of lubricating oil to the moving parts to prevent wear and tear of rust.
- 3, Keep the car away from fire and direct sunlight. Place it stably, not upside down. The car shall be stored indoors or outdoors under cover.
- 4, The car should be kept away from hot items, such as stoves or heaters, or the plastic parts will melt. When charging, the car should be kept away from inflammable materials to prevent it from catching fire.
- 5, Charge in time after use. Charging should be done by adults. If the product is going to be unused for a long time, it must be fully charged. Charge it every month so as to extend the battery lifespan.
- 6, A soft cloth must be used to clean the car. Do not use chemical solvents to clean the plastic parts. Do not use soap or water to clean the car. Driving in rainy or snowy weather, water can damage the motor, battery and circuit system.
- 7, When stopping or storing the car, please cut off the power and make sure all switches are in the 'STOP' or 'OFF' position.
- 8, Do not use fuses different from the specifications of this product.
- 9, Do not change the product structure and circuit system. Maintenance and repair work must be done under the guidance of the professional or technical personnel in place.
- 10, Do not use the product for other purposes. Put the battery in the right polarity.
- 11, Battery negative short circuit is prohibited. Non-rechargeable batteries cannot be charged.
- 12, Rechargeable batteries can only be charged under the supervision of the adult.
- 13, Do not mix old and new batteries or different types of batteries.
- 14, The battery running out of power should be removed from the car properly and not allowed to be played with by children.
- 15, Disconnect the batteries completely when not in use and do not allow children to play with them.

# TROUBLESHOOTING

Car does not move or power on	If "power" switch is in OFF position
	If the fuse is not functioning properly
	If the battery is not connected, check the red and black wires.
	If the charger is plugged in, car will not power on. Unplug charger.
	If the pedal switch is not functioning properly
	If the wheels are stuck and cannot move
Car moves slowly	If the battery is not fully charged. Need to be charged in time
	If there is an issue with the wheels
	If rider weight exceeds specifications
Battery does not charge	If the charger is malfunctioning
	If the battery lost its capacity
	If the charger and battery connection are charged



**MADE IN CHINA**

Manufactured under license by

**INITIATE**

**PLANB**

**DREAM TO INNOVATE**



**PLAN B INTERNATIONAL HONG KONG LTD**  
 Suite 1505, 15th Floor, Chinachem Golden Plaza,  
 77 Mody Rd, Tsimshatsui East, Kowloon, Hong Kong.